



Austrian Institute of Construction Engineering  
Schenkenstrasse 4 | T+43 1 533 65 50  
1010 Vienna | Austria | F+43 1 533 64 23  
www.oib.or.at | mail@oib.or.at



## European Technical Assessment

**ETA-12/0601**  
of 21.12.2018

General part

**Technical Assessment Body issuing the European Technical Assessment**

Österreichisches Institut für Bautechnik (OIB)  
Austrian Institute of Construction Engineering

**Trade name of the construction product**

Rock and soil anchor system SAS with  
prestressing steel thread bars Y1050H, diameter  
17.5 to 47 mm

**Product family to which the construction product belongs**

Kit for rock and soil anchors – Kit with thread bars  
of prestressing steel

**Manufacturer**

Stahlwerk Annahütte  
Max Aicher GmbH & Co. KG  
83404 Ainring-Hammerau  
Germany

**Manufacturing plant**

Stahlwerk Annahütte  
Max Aicher GmbH & Co. KG  
83404 Ainring-Hammerau  
Germany

**This European Technical Assessment contains**

49 pages including Annexes 1 to 28, which form  
an integral part of this assessment.

**This European Technical Assessment is issued in accordance with Regulation (EU) № 305/2011, on the basis of**

EAD 160045-00-0102, European Assessment  
Document for Kit for rock and soil anchors – Kit  
with thread bars of prestressing steel.

**This European Technical Assessment replaces**

European technical approval ETA-12/0601 with  
validity from 12.06.2013 to 11.06.2018.

**Table of contents**

**EUROPEAN TECHNICAL ASSESSMENT ETA-12/0601 OF 21.12.2018 ..... 1**

GENERAL PART..... 1

TABLE OF CONTENTS ..... 2

REMARKS ..... 5

**SPECIFIC PARTS..... 5**

1 TECHNICAL DESCRIPTION OF THE PRODUCT ..... 5

1.1 General ..... 5

ROCK AND SOIL ANCHOR SYSTEM..... 6

1.2 General ..... 6

1.3 Designation and range of rock and soil anchors ..... 6

1.4 Tendon..... 7

1.5 Anchorage..... 7

1.6 Coupler assemblies..... 7

1.7 Load transfer to the structure..... 7

1.8 Corrosion protection systems ..... 8

    1.8.1 Temporary rock and soil anchor ..... 8

    1.8.2 Temporary rock and soil anchor with extended working life..... 8

    1.8.3 Permanent rock and soil anchor ..... 9

COMPONENTS..... 9

1.9 General ..... 9

1.10 Tensile element, thread bar in prestressing steel..... 10

1.11 Coupler ..... 10

1.12 Anchor plate ..... 10

1.13 Domed nut..... 10

1.14 Corrosion protection components..... 10

1.15 Ancillary components ..... 10

1.16 Cement mortar ..... 11

2 SPECIFICATION OF THE INTENDED USES IN ACCORDANCE WITH THE APPLICABLE EUROPEAN ASSESSMENT DOCUMENT (HEREINAFTER EAD) ..... 11

2.1 Intended uses..... 11

2.2 Assumptions..... 11

    2.2.1 General ..... 11

    2.2.2 Packaging, transport and storage..... 11

    2.2.3 Design..... 12

    2.2.4 Installation..... 13

        2.2.4.1 General ..... 13

        2.2.4.2 Temporary rock and soil anchor ..... 14

        2.2.4.3 Temporary rock and soil anchor with extended working life..... 14

        2.2.4.4 Permanent rock and soil anchor ..... 14

electronic copy

2.3	Assumed working life .....	14
3	PERFORMANCE OF THE PRODUCT AND REFERENCES TO THE METHODS USED FOR ITS ASSESSMENT .....	15
3.1	Essential characteristics .....	15
3.2	Product performance .....	18
3.2.1	Mechanical resistance and stability .....	18
3.2.1.1	Resistance to static load of anchorages and coupling assemblies .....	18
3.2.1.2	Resistance to fatigue of anchorages and coupling assemblies .....	18
3.2.1.3	Load transfer to the structure .....	18
3.2.1.4	Corrosion protection of temporary anchor .....	18
3.2.1.5	Corrosion protection of temporary anchor with extended working life .....	18
3.2.1.6	Corrosion protection of permanent anchor .....	18
3.2.1.7	Transition anchorage to free length of temporary anchor .....	18
3.2.1.8	Transition anchorage to free length of temporary anchor with extended working life .....	18
3.2.1.9	Transition anchorage to free length of permanent anchor .....	18
3.2.1.10	Transition anchorage to free length – Tightness .....	18
3.2.1.11	Hardness of nut, anchor plate, and coupler .....	18
3.3	Assessment methods .....	19
3.4	Identification .....	19
4	ASSESSMENT AND VERIFICATION OF CONSTANCY OF PERFORMANCE (HEREINAFTER AVCP) SYSTEM APPLIED, WITH REFERENCE TO ITS LEGAL BASE .....	19
4.1	System of assessment and verification of constancy of performance .....	19
4.2	AVCP for construction products for which a European Technical Assessment has been issued .....	19
5	TECHNICAL DETAILS NECESSARY FOR THE IMPLEMENTATION OF THE AVCP SYSTEM, AS PROVIDED FOR IN THE APPLICABLE EAD .....	20
5.1	Tasks for the manufacturer .....	20
5.1.1	Factory production control .....	20
5.1.2	Declaration of performance .....	20
5.2	Tasks for the notified product certification body .....	20
5.2.1	Initial inspection of the manufacturing plant and of factory production control .....	20
5.2.2	Continuing surveillance, assessment, and evaluation of factory production control .....	20
5.2.3	Audit-testing of samples taken by the notified product certification body at the manufacturing plant or at the manufacturer's storage facilities .....	21
<b>ANNEXES</b>	.....	<b>22</b>
ANNEX 1	TEMPORARY ROCK AND SOIL ANCHOR .....	22
ANNEX 2	TEMPORARY ROCK AND SOIL ANCHOR WITH EXTENDED WORKING LIFE .....	23
ANNEX 3	PERMANENT ROCK AND SOIL ANCHOR .....	24
ANNEX 4	COUPLING ASSEMBLIES .....	25
ANNEX 5	PROOF FORCES AND LOCK-OFF FORCES .....	26
ANNEX 6	CENTRE SPACING AND EDGE DISTANCE – ADDITIONAL REINFORCEMENT .....	27
ANNEX 7	PRESTRESSING STEEL THREAD BAR – NOMINAL DIMENSIONS AND MASS – RIB GEOMETRY .....	28
ANNEX 8	PRESTRESSING STEEL THREAD BAR – MECHANICAL TECHNOLOGICAL CHARACTERISTICS .....	29
ANNEX 9	INNER GROUT – SPECIFICATION .....	30
ANNEX 10	HEAT SHRINKING SLEEVE – SPECIFICATION .....	31

ANNEX 11	COMPONENTS – DOMED NUT, SQUARE ANCHOR PLATE, WELDED STEEL TUBE – DIMENSIONS.....	32
ANNEX 12	COMPONENTS – COUPLER WITH SET SCREWS, LOAD TRANSFER PLATES – DIMENSIONS .....	33
ANNEX 13	COMPONENTS – ANGLE COMPENSATION TUBE, COUPLER TUBE – DIMENSIONS .....	34
ANNEX 14	COMPONENTS – STEEL CAP – DIMENSIONS .....	35
ANNEX 15	COMPONENTS – PLASTIC CAP WITH SCREW SOCKET – DIMENSIONS.....	36
ANNEX 16	COMPONENTS – CORRUGATED PLASTIC SHEATHING, HEAT SHRINKING SLEEVE – DIMENSIONS.....	37
ANNEX 17	COMPONENTS – SMOOTH SHEATHING – DIMENSIONS.....	38
ANNEX 18	COMPONENTS – BASKET SPACER, PROFILE RING, SEALING RING – DIMENSIONS.....	39
ANNEX 19	COMPONENTS – PLASTIC CORD, MAT SPACER, INJECTION AND END CAP – DIMENSIONS.....	40
ANNEX 20	MATERIAL SPECIFICATIONS.....	41
ANNEX 21	CONTENTS OF THE PRESCRIBED TEST PLAN.....	42
ANNEX 22	CONTENTS OF THE PRESCRIBED TEST PLAN.....	43
ANNEX 23	AUDIT TESTING .....	44
ANNEX 24	AUDIT TESTING .....	45
ANNEX 25	ESSENTIAL CHARACTERISTICS FOR THE INTENDED USES .....	46
ANNEX 26	ESSENTIAL CHARACTERISTICS FOR THE INTENDED USES .....	47
ANNEX 27	REFERENCE DOCUMENTS.....	48
ANNEX 28	REFERENCE DOCUMENTS.....	49

## Remarks

Translations of the European Technical Assessment in other languages shall fully correspond to the original issued document and should be identified as such.

Communication of the European Technical Assessment, including transmission by electronic means, shall be in full. However, partial reproduction may be made with the written consent of Österreichisches Institut für Bautechnik. Any partial reproduction has to be identified as such.

## Specific parts

### 1 Technical description of the product

#### 1.1 General

The European Technical Assessment<sup>1</sup> – ETA – applies to a kit, the

### **Rock and soil anchor system SAS with prestressing steel thread bars Y1050H, diameter 17.5 to 47 mm,**

comprising the following components.

– Tendon

The bar tendon of the rock and soil anchor is with one single tensile element.

– Tensile element

Tensile element is a continuously threaded steel bar of prestressing steel Y1050H according to prEN 10138-4<sup>2</sup>. The continuous thread is provided by ribs, hot rolled along the entire length of the bar – thread bar. Due to the continuous thread, the individual thread bars can be anchored at any given point and to obtain the required tendon length, the thread bars can be coupled at any given point.

Nominal diameters and strength characteristics of the thread bar in prestressing steel are given in Table 1.

**Table 1** Tensile elements

Nominal diameter	Nominal yield strength	Nominal tensile strength
Ø	R <sub>p0.1</sub>	R <sub>m</sub>
mm	N/mm <sup>2</sup>	N/mm <sup>2</sup>
17.5, 26.5, 32, 36, 40, and 47	950	1050

NOTE 1 MPa = 1 N/mm<sup>2</sup>

– Anchorage

The thread bar is anchored with a domed nut in steel and a square anchor plate in steel. Load transfer to structural concrete is without or with additional reinforcement.

<sup>1</sup> ETA-12/0601 was firstly issued in 2013 as European technical approval with validity from 12.06.2013 and converted and amended in 2018 to European Technical Assessment ETA-12/0601 of 21.12.2018.

<sup>2</sup> Standards and other documents referred to in the European Technical Assessment are listed in Annex 27 and Annex 28.

- Coupler  
The thread bars are jointed with steel couplers that are secured against unscrewing.
- Corrosion protection system  
Temporary rock and soil anchors, temporary rock and soil anchors with extended working life, and permanent rock and soil anchors are provided with corrosion protection systems, adapted to the intended working life.
  - Fixed anchor length  
Corrosion protection of fixed anchor length is by a cover of cement mortar on the thread bar or by encapsulation with corrugated plastic sheathing and grouting the void between thread bar and corrugated plastic sheathing.
  - Free anchor length  
At free anchor length the thread bar is corrosion protected by smooth sheathing, corrosion protection coating with smooth sheathing, or encapsulation with corrugated plastic sheathing and grouting the void between thread bar and corrugated plastic sheathing. For debonding, the encapsulated thread bar is provided with a smooth sheathing. At the ends, the smooth sheathing is sealed to thread bar or corrugated plastic sheathing.
  - Transition anchorage to free anchor length  
On the anchor plate a steel tube is tightly welded. Steel tube and sheathing of the thread bar overlap. Except for temporary rock and soil anchors, a sealing is installed between smooth or corrugated plastic sheathing and the void between steel tube and thread bar is filled with corrosion protection filling material.
  - Anchorage  
At the anchorage, corrosion protection is applied on thread bar and domed nut and a cap is attached to the anchor plate. For temporary rock and soil anchors, corrosion protection of anchorage is only required for corrosive environments and aesthetic reasons.
  - Coupler assemblies  
Corrosion protection of coupler assemblies is provided by a cover of cement mortar, heat shrinking sleeve, or combinations of coupler tube sealed to adjacent sheathings and corrosion protection filling material.
- Ancillary components  
Ancillary components are spacers to provide cover of grout inside the corrugated plastic sheathing – inner grout –, to ensure the distance between thread bar or plastic sheathing and bore hole wall, and to facilitate grouting of the corrugated plastic sheathing.

## **Rock and soil anchor system**

### **1.2 General**

The rock and soil anchor is installed by placing the thread bar, possibly jointed with couplers, and provided with corrosion protection according to the intended working life in the centre of a pre-drilled borehole. Along the fixed anchor length, the annular void between rock and soil anchor and bore hole wall is injected with cement mortar. At the protruding part of the rock and soil anchor, the anchorage is installed. After stressing the rock and soil anchor, the final corrosion protection is applied.

### **1.3 Designation and range of rock and soil anchors**

The rock and soil anchor of the Rock and soil anchor system SAS with prestressing steel thread bars Y1050H, diameter 17.5 to 47 mm, is designated by the nominal diameter of the thread bar.

The rock and soil anchor system includes rock and soil anchor with the following nominal diameters of the thread bar,  $\varnothing = 17.5, 26.5, 32, 36, 40,$  and 47 mm.

The characteristic values of maximum force of thread bars are given in Annex 8.

#### **1.4 Tendon**

The tendon comprises a thread bar. The required length of the tendon is achieved by jointing the necessary number of thread bars with couplers. To attain the intended working life, the tendon is provided with appropriate corrosion protection.

Inherent to the installation of the rock and soil anchor, the fixed anchor length provides a body of cement mortar between tendon and borehole wall with a thickness of at least 10 mm. Concentric position of tendon and minimum thickness of body of cement mortar are ensured by spacers. The cement mortar meets the requirements of EN 1537, taking into consideration the exposure classes according to EN 206.

Along the free anchor length, a smooth sheathing is slipped over the tendon.

#### **1.5 Anchorage**

The anchorage comprises a domed nut and a square anchor plate, see Annex 11. As part of the corrosion protection system, a steel tube is tightly welded on the anchor plate. Steel tube and sheathing of free anchor length overlap and a sealing between steel tube and sheathing can be installed.

A larger angle deviation may be achieved using an angle compensation tube, see Annex 13. Boreholes with large diameters are spanned with load transfer plates in steel, see Annex 12.

#### **1.6 Coupler assemblies**

Tensile elements, i.e. thread bars, are jointed with couplers. The coupler is secured against unscrewing with screws. Overlap of heat shrinking sleeve and adjacent elements, i.e. thread bar or corrugated plastic sheathing, is at least 75 mm. Different versions of coupler assemblies are shown in Annex 4 and the dimensions of the couplers in Annex 12.

The installed coupler does not impede the free elongation of the tendon during stressing.

#### **1.7 Load transfer to the structure**

The load is transferred from the tendon via domed nut and anchor plate to the structure.

Concrete structures directly loaded by the anchorage are executed without or with additional reinforcement.

- Centre spacing and edge distance, concrete compressive strength, and additional reinforcement are specified in Annex 6.
- Additional reinforcement is placed at the anchorage, concentric with regard to the tendon. This reinforcement confines the concrete and absorbs bursting forces due to spreading of the load from the anchorage into the concrete structure – bursting reinforcement.
- For concrete structures without additional reinforcement, the area around the centric rock and soil anchor with outer dimensions corresponding to the centre distances specified in Annex 6, is reinforced as follows.
  - The reinforcement is at least 50 kg/m<sup>3</sup>.
  - Only the loaded depth of the concrete structure down from the anchor plate is considered.
  - Reinforcement already placed in that area for other reasons may be fully taken into consideration.
  - The reinforcement does not need to be detailed and placed as bursting reinforcement.



If load transfer plates, see Annex 12, are designed and installed according to Clause 2.2.3, e.g. as shown in Annex 1, Annex 2, Annex 3, and Annex 6, a minimum concrete grade of  $\geq$  C30/37 is used. However, the minimum centre and edge distances as specified in Annex 6 are not reduced.

## 1.8 Corrosion protection systems

### 1.8.1 Temporary rock and soil anchor

The temporary rock and soil anchor is intended for up to 2 years working life. Annex 1 shows a schematic representation of the corrosion protection of temporary anchors. The most important components of the corrosion protection system are.

- Body of cement mortar, thickness  $\geq$  10 mm, between thread bar and borehole wall along the fixed anchor length. Concentric position of thread bar and minimum thickness of body of cement mortar are ensured by spacers.
- Smooth sheathing, thickness  $t \geq$  1.5 mm, in the free anchor length, sealed at the ends with an adhesive tape to prevent the ingress of water.
- Coupler in the free anchor length inside a coupler tube, thickness  $t \geq$  2 mm, sealed at the ends with heat shrinking sleeves.
- Coupler at the transition free anchor length to fixed anchor length.
- The steel tube welded onto the anchor plate overlaps the smooth sheathing at the end of the free anchor length.
- For temporary rock and soil anchors, corrosion protection of anchorage is only required for corrosive environments and aesthetic reasons.

### 1.8.2 Temporary rock and soil anchor with extended working life

The temporary rock and soil anchor with extended working life is intended for up to 7 years working life. Annex 2 shows a schematic representation of the corrosion protection of temporary anchors with extended working life. The most important components of the corrosion protection system are.

- Body of cement mortar, thickness  $\geq$  10 mm, between thread bar and borehole wall along the fixed anchor length. Concentric position of thread bar and minimum thickness of body of cement mortar are ensured by spacers.
- In the free anchor length, the thread bar is coated with corrosion protection material.
- Smooth sheathing, thickness  $t \geq$  1.5 mm, in the free anchor length, sealed at the ends with heat shrinking sleeves to prevent the ingress of water.
- Coupler in the free anchor length, coated with corrosion protection material, inside a coupler tube, thickness  $t \geq$  2 mm, sealed at the ends with heat shrinking sleeves.
- Coupler at the transition free anchor length to fixed anchor length.
- The steel tube welded onto the anchor plate overlaps the smooth sheathing at the end of the free anchor length and is sealed off against the smooth sheathing with a sealing ring.
- At the transition between anchorage and free anchor length the void between tendon and steel tube is filled with corrosion protection material.
- After tensioning, the thread bar protrusion is coated with corrosion protection material and a steel or plastic protective cap is tightly attached to the anchor plate.



### 1.8.3 Permanent rock and soil anchor

The permanent rock and soil anchor is intended for up to 100 years working life. Annex 3 shows a schematic representation of the corrosion protection of permanent anchors. The most important components of the corrosion protection system are.

- Permanent rock and soil anchors are protected against corrosion by encapsulating the thread bar in a corrugated plastic sheathing with a wall thickness of  $\geq 1.0$  mm. The bottom end of the rock and soil anchor is closed with a cap. Joints within the encapsulation are sealed with an adhesive tape. The annular void between thread bar and corrugated plastic sheathing is grouted according to EN 445, EN 446, and EN 447. The thickness of the cover of cement grout on the thread bar inside the corrugated plastic sheathing is at least 5 mm. Concentric position of thread bar and minimum thickness of cover of cement grout are ensured by a plastic cord helically wound around the thread bar or by spacers. Encapsulation with grouting of the annular void is carried out at the manufacturing plant.
- Body of cement mortar, thickness  $\geq 10$  mm, between encapsulated tendon and borehole wall along the fixed anchor length. Concentric position of thread bar and minimum thickness of body of cement mortar are ensured by spacers.
- In the free anchor length, a smooth sheathing, thickness  $\geq 1.5$  mm, is slipped over the encapsulated tendon and sealed off against the corrugated plastic sheathing with an adhesive tape.
- Coupler in the free anchor length are placed inside a coupler tube, thickness  $t \geq 2$  mm, filled with corrosion protection material and sealed at the ends with heat shrinking sleeves.
- Coupler at the transition free anchor length to fixed anchor length is protected with a double layer of heat shrinking sleeve. Overlap of heat shrinking sleeve and adjacent elements, i.e. thread bar or corrugated plastic sheathing, is at least 75 mm.
- A steel tube is tightly welded onto the anchor plate. Steel tube and anchor plate are provided with an appropriate corrosion protection according to EN ISO 12944-5.
- The steel tube overlaps the corrugated plastic sheathing at the end of the free anchor length and is sealed off against the corrugated plastic sheathing with profile ring sealing. At the transition anchorage to free anchor length, the void between tendon and steel tube is filled with corrosion protection filling material.
- Following tensioning the rock and soil anchor,
  - a protective cap in steel, hot dip galvanised according to EN ISO 1461 or
  - a protective cap in steel, provided with an appropriate corrosion protection according to EN ISO 12944-5 or
  - a plastic protective cap is tightly attached to the anchor plate and filled with corrosion protection filling material.

If the anchorage is embedded in concrete, a cap is not required.

## Components

### 1.9 General

The components of the Rock and soil anchor system SAS with prestressing steel thread bars Y1050H, diameter 17.5 to 47 mm, conform to representations and dimensions in Annex 7, Annex 11, Annex 12, Annex 13, Annex 14, Annex 15, Annex 16, Annex 17, Annex 18, and Annex 19 and material specifications in Annex 8, Annex 9, Annex 10, and Annex 20. Component specifications and tolerances of the components not given in the Annexes are specified to the technical data given in the technical file<sup>3</sup> of the European technical approval.

<sup>3</sup> The technical file of the European Technical Assessment is deposited at Österreichisches Institut für Bautechnik.

### 1.10 Tensile element, thread bar in prestressing steel

The tensile element is a hot rolled, in-line heat treated, stretched and tempered prestressing steel bar Y1050H with a continuous right-hand thread – thread bar.

The most important characteristics are, see Annex 7 and Annex 8.

- Nominal diameter 17.5, 26.5, 32, 36, 40, and 47 mm
- Characteristic yield strength  $R_{p0.1} = 950 \text{ N/mm}^2$
- Characteristic tensile strength  $R_m = 1\,050 \text{ N/mm}^2$
- Elongation at maximum force  $A_{gt} \geq 5 \%$

The thread bar is in particular suitable for geotechnical applications. Welding and bending are possible in principle, but not intended for rock and soil anchors.

### 1.11 Coupler

The tensile elements, thread bars, are jointed with couplers. The coupler is secured against unscrewing with screws. Different versions of coupler assemblies are shown in Annex 4 and the dimensions of the coupler in Annex 12.

The installed coupler does not impede the free elongation of the tendon.

### 1.12 Anchor plate

The anchor plate is a square steel plate with a centric bore. On one side a cone is machined to accommodate the domed nut. As part of the corrosion protection system a steel tube is tightly welded on the anchor plate.

Anchor plate with welded steel tube and with dimensions are shown in Annex 11.

### 1.13 Domed nut

The domed nut is in steel and anchors the thread bar. The spherical shape sitting in the cone of the anchor plate permits compensation of angular deviations.

Domed nut and dimensions are shown in Annex 11.

### 1.14 Corrosion protection components

Components of the corrosion protection system are corrugated and smooth plastic sheathing, heat shrinking sleeve, grout inside the corrugated plastic sheathing, sealing at the transition anchorage to free anchor length, coupler tube, corrosion protection filling material at the anchorage, and cap in steel or plastic.

Components of the corrosion protection system with specifications and dimensions are shown in Annex 9, Annex 10, Annex 13, Annex 14, Annex 15, Annex 16, Annex 17, and Annex 18.

### 1.15 Ancillary components

Spacers to provide cover of grout inside the corrugated plastic sheathing are a plastic cord or plastic mat spacers, see Annex 19. The plastic cord is helically wound around the thread bar with a pitch  $\leq 0.5 \text{ m}$  and the mat spacers are installed in a distance of  $\leq 1.0 \text{ m}$ .

In the fixed anchor length, basket spacers in plastic are fastened to thread bar or corrugated plastic sheathing in a distance of  $\leq 1.5 \text{ m}$ , see Annex 18. With the basket spacers the distance to the bore hole wall is ensured.

For grouting and to fully encase the thread bar, the corrugated plastic sheathing is completed with injection cap and end cap, see Annex 19.

Ancillary components are part of the kit, however, for them no essential characteristic is assessed.

## 1.16 Cement mortar

Cement mortar is inherent in the rock and soil anchor system. Along the fixed anchor length, the body of cement mortar between thread bar or corrugated plastic sheathing and borehole wall transfers the load from thread bar to bore hole wall and takes a part of corrosion protection.

The cement mortar meets the requirements of EN 1537, taking into consideration the exposure classes according to EN 206.

Cement mortar is provided on the construction site, is not subject ETA and no essential characteristic is assessed for cement mortar.

## 2 Specification of the intended uses in accordance with the applicable European Assessment Document (hereinafter EAD)

### 2.1 Intended uses

The Rock and soil anchor system SAS with prestressing steel thread bars Y1050H, diameter 17.5 to 47 mm, is intended to stabilise the construction ground by active introduction of prestressing forces according to the principles for the execution of geotechnical works. Construction ground refers to both, rock and soil.

Rock and soil anchors are temporary, temporary with extended working life, or permanent according to Table 2.

**Table 2** Intended uses of the rock and soil anchor

Line №	Intended use	Working life
1	Temporary rock and soil anchor	Up to 2 years
2	Temporary rock and soil anchor with extended working life	Up to 7 years
3	Permanent rock and soil anchor	Up to 100 years

### 2.2 Assumptions

#### 2.2.1 General

Concerning product packaging, transport, storage, maintenance, replacement, and repair it is the responsibility of the manufacturer to undertake the appropriate measures and to advise his clients on transport, storage, maintenance, replacement, and repair of the product as he considers necessary.

#### 2.2.2 Packaging, transport and storage

Advice on packaging, transport, and storage includes

- Temporary protection of thread bars and the other components in order to prevent damaging corrosion during transport from the production site to the job site. Light surface rust is acceptable.
- Transportation, storage, and handling of the thread bars and other components in a manner as to avoid damage by mechanical or chemical impact.
- Protection of thread bars and other components from moisture.

### 2.2.3 Design

Design is according to the Eurocodes.

For verification of rock and soil anchor applications with the Rock and soil anchor system SAS with prestressing steel thread bars Y1050H, diameter 17.5 to 47 mm, the following items are considered.

- The rock and soil anchor is only subjected to axial tensile loading.
- The design value for the ultimate limit state of the rock and soil anchor is assumed according to Eurocode 2 with a partial safety factor of  $1.15^4$  against attainment of the characteristic force at yield strength,  $F_{p0.1}$ .
- The load-bearing capacity of the tendon, comprising the components thread bar, coupler, and anchorage, is 100 % relative to the characteristic maximum force,  $F_{pk}$ , of the thread bar. The values in Annex 8 are taken as a basis.
- The capacity of the rock and soil anchors is determined according to Eurocode 7 and EN 1537, based on investigation, suitability and acceptance tests.
- The construction works is designed as to form a redundant structure according to Eurocode 0. Structures with only one single rock and soil anchor is not executed.
- The stress ranges at coupler assembly and anchorage given Table 3 were determined in fatigue tests at an upper force of  $0.65 \cdot F_{pk}$  and up to  $2 \cdot 10^6$  load cycles.
- The parameters of the S-N curve for coupler and anchor head with anchor plate are specified in EN 1992-1-1 and given in Table 4.
- Minimum centre and edge distances are given in Annex 6 without and with additional reinforcement and for a concrete cube compressive strength of  $f_{cm, 0, \text{cube } 150} \geq 25 \text{ N/mm}^2$ .
- For load introduction from the thread bar through the anchorage into the structure Eurocode 2 applies. Minimum centre spacing and edge distance are given in Annex 6 for a concrete cube compressive strength of  $\geq 25 \text{ N/mm}^2$  and with and without additional reinforcement. If centre spacing and edge distance, concrete compressive strength, and additional reinforcement are conformed to, verification of load transfer to structural concrete has been delivered. The forces outside of the bursting reinforcement or the region with outer dimensions corresponding to the centre distances require verification and, where appropriate, are covered by appropriate reinforcement.
- For load transfer without additional reinforcement, the area around the rock and soil anchor is reinforced according to Clause 1.7.
- Punching of the anchorage needs to be considered in any case.
- Boreholes with large diameters are spanned with load transfer plates in steel. The load transfer plates are designed according to Eurocode 3 as to permit a force of  $1.1 \cdot F_{pk}$  being transferred into the substructure.

Where

$F_{pk}$  ..... Nominal maximum force of the thread bar, see Annex 8

- Alternatively the load can be transferred from the anchorage to the structure via a steel member designed according to Eurocode 3. The steel member has dimensions as to permit a force of  $1.1 \cdot F_{pk}$  being transferred into the structure.
- To verify elongations during stressing, a slip value of 3 mm is assumed for the coupler and 3 mm at the anchorage for load transfer from the jack to the structure.

<sup>4</sup> Recommended partial safety factor to be applied in the absence of applicable standards and regulations in force at the place of use.

- With a compressive strength of cement mortar of  $\geq 40 \text{ N/mm}^2$ , a characteristic bond strength of  $6 \text{ N/mm}^2$  can be assumed.
- Recommended proof forces and lock-off forces are listed in Annex 5.

**Table 3** Stress range verified in fatigue tests

Nominal diameter $\varnothing$	Stress range	
	Coupler assembly	Anchorage with anchor plate
mm	$\text{N/mm}^2$	$\text{N/mm}^2$
17.5 to 47	80	80

**Table 4** Parameter of the S-N curve for coupler and anchor head with anchor plate

Nominal diameter $\varnothing$	Parameter of the S-N curve
	Coupler Anchor head with anchor plate
mm	—
17.5 to 47	S-N curve with $\Delta\sigma_{Rsk} = 80 \text{ N/mm}^2$ with $N = 2 \cdot 10^6$ $k_1 = 5, k_2 = 5$ $N^* = 1 \cdot 10^n, n = 6$

Where

- $\Delta\sigma_{Rsk}$  ..... Stress range
- N ..... Number of load cycles
- $k_1, k_2$  ..... Stress exponents of the S-N curve according to EN 1992-1-1, Table 6.4N
- $N^*$  ..... Number of load cycles at the transition from  $k_1$  to  $k_2$

## 2.2.4 Installation

### 2.2.4.1 General

It is assumed that the product will be installed according to the manufacturer's instructions or – in absence of such instructions – according to the usual practice of the building professionals.

Assembly and installation of the Rock and soil anchor system SAS with prestressing steel thread bars Y1050H, diameter 17.5 to 47 mm, is only carried out by appropriately qualified specialist companies with the required resources and experience in the execution of geotechnical works.

The principles for the application and installation of temporary and permanent rock and soil anchors are specified in EN 1537 that includes comprehensive information and data on site investigation, construction materials and construction products, design considerations, installation and execution as well as testing, supervision and monitoring.

According to the local conditions, bursting out of the tendon in case of a bar failure is prevented.

The length of the rock and soil anchor is obtained by jointing the necessary number of thread bars with couplers. The couplers are secured against unscrewing.

The rock and soil anchor is centrally installed into a pre-drilled borehole and along the fixed anchor length injected with cement mortar. Thereby, the existing geotechnical conditions are taken into consideration. The fixed anchor length of all installed rock and soil anchors have a system inherent body of cement mortar between thread bar or corrugated plastic sheathing and borehole wall. The cement mortar conforms to EN 1537. The cement type is selected dependent on the aggressiveness of the soil according to EN 206. The water to cement ratio is appropriate for the actual conditions on the construction site. Alternatively, grout in accordance with EN 445, EN 446 and EN 447 may be used. To improve the bonding strength to the ground, post-grouting can be carried out.

Chemical agents that are aggressive to the cement mortar are considered by use of suitable cements.

NOTE 1 Aggressive chemical agents to that cement mortar cannot resist are possible.

NOTE 2 The aggressiveness of the chemical agents may be determined according to EN 206.

After the cement mortar has set and sufficiently hardened, the anchorage is installed and the rock and soil anchor is stressed. See Annex 5 for the recommended lock-off force.

#### 2.2.4.2 Temporary rock and soil anchor

The cover of cement mortar on the thread bar along the fixed anchor length is  $\geq 10$  mm. The cover of cement mortar is ensured by spacers at a distance of  $\leq 1.5$  m. A smooth sheathing is slipped over the tendon in the free anchor length. For further details on the corrosion protection and the installation of coupler assembly and anchorage see Clause 1.8.1 and Annex 1.

#### 2.2.4.3 Temporary rock and soil anchor with extended working life

The cover of cement mortar on the thread bar along the fixed anchor length is  $\geq 10$  mm. The cover of cement mortar is ensured by spacers at a distance of  $\leq 1.5$  m. In the free anchor length, the thread bar is coated with a corrosion protection material and a smooth sheathing is slipped over the tendon. For further details on the corrosion protection and the installation of couplers and anchorages see Clause 1.8.2 and Annex 2.

#### 2.2.4.4 Permanent rock and soil anchor

The tendon is encapsulated with a corrugated plastic sheathing in the free and fixed anchor length. The annular void between thread bar and corrugated plastic sheathing is grouted at the manufacturing plant. Corrugated plastic sheathing with a thickness of  $\geq 1.0$  mm and an inner cement grout layer of at least 5 mm between thread bar and corrugated plastic sheathing are applied. The thread bar is centred in the corrugated plastic sheathing with a plastic cord or plastic spacers. Grouting of the corrugated plastic sheathing is carried out according to defined operating procedures. The sheathed and grouted tendon is kept in place until the cement grout has sufficiently set and hardened. This is attained not before 24 hours after grouting.

Along the fixed anchor length, the cover of cement mortar on the encapsulated tendon is  $\geq 10$  mm. The cover of cement mortar is ensured by spacers at a distance of  $\leq 1.5$  m. A smooth sheathing is slipped over the encapsulated tendon in the free anchor length. For further details on the corrosion protection and the installation of couplers and anchorages see Clause 1.8.3 and Annex 3.

### 2.3 Assumed working life

The European Technical Assessment is based on an assumed working life of the Rock and soil anchor system SAS with prestressing steel thread bars Y1050H, diameter 17.5 to 47 mm, of up to 2 years for temporary anchors, of up to 7 years for temporary anchors with extended working life, and of up to 100 years for permanent anchors, provided that the Rock and soil anchor system SAS with prestressing steel thread bars Y1050H, diameter 17.5 to 47 mm, is subject to appropriate



installation, use, and maintenance, see Clause 2.2. These provisions are based upon the current state of the art and the available knowledge and experience.

In normal use conditions, the real working life may be considerably longer without major degradation affecting the basic requirements for construction works<sup>5</sup>.

The indications given as to the working life of the construction product cannot be interpreted as a guarantee, neither given by the product manufacturer or his representative nor by EOTA nor by the Technical Assessment Body but are regarded only as a means for expressing the expected economically reasonable working life of the product.

### 3 Performance of the product and references to the methods used for its assessment

#### 3.1 Essential characteristics

The performances of the Rock and soil anchor system SAS with prestressing steel thread bars Y1050H, diameter 17.5 to 47 mm, for the essential characteristics are given in Table 5. In Annex 25 and Annex 26 the combinations of essential characteristics and corresponding intended uses are listed.

**Table 5** Essential characteristics and performances of the rock and soil anchor

No	Essential characteristic	Product performance
Basic requirement for construction works 1: Mechanical resistance and stability		
1	Resistance to static load of anchorages and coupling assemblies	See Clause 3.2.1.1.
2	Resistance to fatigue of anchorages and coupling assemblies	See Clause 3.2.1.2.
3	Load transfer to the structure	See Clause 3.2.1.3.
4	Corrosion protection of temporary anchor	See Clause 3.2.1.4.
5	Corrosion protection of temporary anchor with extended working life	See Clause 3.2.1.5.
6	Corrosion protection of permanent anchor	See Clause 3.2.1.6.
7	Transition anchorage to free length of temporary anchor	See Clause 3.2.1.7.
8	Transition anchorage to free length of temporary anchor with extended working life	See Clause 3.2.1.8.
9	Transition anchorage to free length of permanent anchor	See Clause 3.2.1.9.
10	Transition anchorage to free length – Tightness	See Clause 3.2.1.10.
11	Crack width in inner grout	See Annex 9.

<sup>5</sup> The real working life of a product incorporated in a specific works depends on the environmental conditions to which that works are subject, as well as on the particular conditions of design, execution, use, and maintenance of that works. Therefore, it cannot be excluded that in certain cases the real working life of the product may also be shorter than the assumed working life.

electronic copy



No	Essential characteristic	Product performance
Thread bar of prestressing steel		
12	Cross-sectional area	See Annex 7.
13	Mass per metre	See Annex 7.
14	Surface geometry	See Annex 7.
15	Strength characteristics	See Annex 8.
16	Modulus of elasticity	See Annex 8.
17	Elongation at maximum force	See Annex 8.
18	Resistance to fatigue	See Annex 8.
19	Stress relaxation	See Annex 8.
20	Constriction at break	See Annex 8.
21	Stress corrosion resistance	See Annex 8.
Nut, anchor plate, and coupler		
22	Shape	See Annex 11 and Annex 12.
23	Dimensions	See Annex 11 and Annex 12.
24	Material	See Annex 20.
25	Hardness	See Clause 3.2.1.11.
Inner grout		
26	Content of aggressive components	See Annex 9.
27	Residue on sieve	See Annex 9.
28	Fluidity, cone	See Annex 9.
29	Fluidity, grout spread	See Annex 9.
30	Bleeding, wick-induced	See Annex 9.
31	Bleeding, inclined tube	See Annex 9.
32	Volume change	See Annex 9.
33	Compressive strength	See Annex 9.
34	Setting time	See Annex 9.
35	Fluid density	See Annex 9.
Heat shrinking sleeve with inner coating		
36	Thickness after shrinking	See Annex 10.
37	Mass per unit area of adhesive	See Annex 10.
38	Tensile strength	See Annex 10.
39	Elongation at break	See Annex 10.
40	Peel strength layer to layer	See Annex 10.

electronic copy

No	Essential characteristic	Product performance
41	Peel strength to the steel surface	See Annex 10.
42	Thermal ageing resistance	See Annex 10.
43	Indentation resistance	See Annex 10.
44	Impact resistance	See Annex 10.
45	Saponification value	See Annex 10.
46	Microbiological resistance	See Annex 10.
47	Water absorption	See Annex 10.
48	Softening point of adhesive	See Annex 10.
49	Oxygen stability of adhesive	See Annex 10.
50	Resistance to salt spray of adhesive	See Annex 10.
51	Content of aggressive components of adhesive	See Annex 10.
Corrugated plastic sheathing		
52	Shape	See Annex 16.
53	Dimensions	See Annex 16.
54	Material	See Annex 20.
Basic requirement for construction works 2: Safety in case of fire		
—	Not relevant. No characteristic assessed.	—
Basic requirement for construction works 3: Hygiene, health, and the environment		
—	No characteristic assessed.	—
Basic requirement for construction works 4: Safety and accessibility in use		
—	Not relevant. No characteristic assessed.	—
Basic requirement for construction works 5: Protection against noise		
—	Not relevant. No characteristic assessed.	—
Basic requirement for construction works 6: Energy economy and heat retention		
—	Not relevant. No characteristic assessed.	—
Basic requirement for construction works 7: Sustainable use of natural resources		
—	No characteristic assessed.	—

## 3.2 Product performance

### 3.2.1 Mechanical resistance and stability

#### 3.2.1.1 Resistance to static load of anchorages and coupling assemblies

The Rock and soil anchor system SAS with prestressing steel thread bars Y1050H, diameter 17.5 to 47 mm, as described in the ETA meets the acceptance criteria of EAD 160045-00-0102, Clause 2.2.1. The characteristic tensile strength,  $R_m$ , of the prestressing steel thread bars is given in Annex 8.

#### 3.2.1.2 Resistance to fatigue of anchorages and coupling assemblies

For resistance to fatigue of anchorages and coupling assemblies see Clause 2.2.3, Table 3

#### 3.2.1.3 Load transfer to the structure

The Rock and soil anchor system SAS with prestressing steel thread bars Y1050H, diameter 17.5 to 47 mm, as described in the ETA meets the acceptance criteria of EAD 160045-00-0102, Clause 2.2.3. The characteristic tensile strength,  $R_m$ , of the prestressing steel thread bars is given in Annex 8.

#### 3.2.1.4 Corrosion protection of temporary anchor

Corrosion protection of the temporary rock and soil anchor is described in Clause 1.8.1.

#### 3.2.1.5 Corrosion protection of temporary anchor with extended working life

Corrosion protection of the temporary rock and soil anchor with extended working life is described in Clause 1.8.2.

#### 3.2.1.6 Corrosion protection of permanent anchor

Corrosion protection of the permanent rock and soil anchor is described in Clause 1.8.3.

#### 3.2.1.7 Transition anchorage to free length of temporary anchor

Corrosion protection of transition anchorage to free length of the temporary rock and soil anchor is described in Clause 1.8.1.

#### 3.2.1.8 Transition anchorage to free length of temporary anchor with extended working life

Corrosion protection of transition anchorage to free length of the temporary rock and soil anchor with extended working life is described in Clause 1.8.2.

#### 3.2.1.9 Transition anchorage to free length of permanent anchor

Corrosion protection of transition anchorage to free length of the permanent rock and soil anchor is described in Clause 1.8.3.

#### 3.2.1.10 Transition anchorage to free length – Tightness

The tightness of transition anchorage to free length of the permanent rock and soil anchor is 0.3 N/mm<sup>2</sup> without leakage.

#### 3.2.1.11 Hardness of nut, anchor plate, and coupler

For hardness of nut, anchor plate, and coupler see Table 6.

**Table 6** Hardness of components

Component	Hardness HBW
Domed nut	≥ 193
Square anchor plate	≥ 127
Coupler	≥ 140

### 3.3 Assessment methods

The assessment of the essential characteristics in Clause 3.1 of the Rock and soil anchor system SAS with prestressing steel thread bars Y1050H, diameter 17.5 to 47 mm, for the intended uses, and in relation to the requirements for mechanical resistance and stability, in the sense of the basic requirements for construction works № 1 of Regulation (EU) № 305/2011, has been made in accordance with EAD 160045-00-0102, Kit for rock and soil anchors – Kit with thread bars of prestressing steel.

### 3.4 Identification

The European Technical Assessment for the Rock and soil anchor system SAS with prestressing steel thread bars Y1050H, diameter 17.5 to 47 mm, is issued on the basis of agreed data that identify the assessed product<sup>6</sup>. Changes to materials, to composition, or to characteristics of the product, or to the production process could result in these deposited data being incorrect. Österreichisches Institut für Bautechnik should be notified before the changes are introduced, as an amendment of the European Technical Assessment is possibly necessary.

## 4 Assessment and verification of constancy of performance (hereinafter AVCP) system applied, with reference to its legal base

### 4.1 System of assessment and verification of constancy of performance

According to Commission Decision 98/456/EC the system of assessment and verification of constancy of performance to be applied to the Rock and soil anchor system SAS with prestressing steel thread bars Y1050H, diameter 17.5 to 47 mm, is System 1+. System 1+ is detailed in Commission Delegated Regulation (EU) № 568/2014 of 18 February 2014, Annex, point 1.1., and provides for the following items.

- (a) The manufacturer shall carry out
  - (i) factory production control;
  - (ii) further testing of samples taken at the manufacturing plant by the manufacturer in accordance with the prescribed test plan<sup>7</sup>.
- (b) The notified product certification body shall decide on the issuing, restriction, suspension, or withdrawal of the certificate of constancy of performance of the construction product on the basis of the outcome of the following assessments and verifications carried out by that body
  - (i) an assessment of the performance of the construction product carried out on the basis of testing (including sampling), calculation, tabulated values, or descriptive documentation of the product;
  - (ii) initial inspection of the manufacturing plant and of factory production control;
  - (iii) continuing surveillance, assessment, and evaluation of factory production control;
  - (iv) audit-testing of samples taken by the notified product certification body at the manufacturing plant or at the manufacturer's storage facilities.

### 4.2 AVCP for construction products for which a European Technical Assessment has been issued

Notified bodies undertaking tasks under System 1+ shall consider the European Technical Assessment issued for the construction product in question as the assessment of the performance of that product. Notified bodies shall therefore not undertake the tasks referred to in Clause 4.1, point (b) (i).

<sup>6</sup> The technical file of the European Technical Assessment is deposited at Österreichisches Institut für Bautechnik.

<sup>7</sup> The prescribed test plan has been deposited with Österreichisches Institut für Bautechnik and is handed over only to the notified product certification body involved in the procedure for the assessment and verification of constancy of performance. The prescribed test plan is also referred to as control plan.

## **5 Technical details necessary for the implementation of the AVCP system, as provided for in the applicable EAD**

### **5.1 Tasks for the manufacturer**

#### **5.1.1 Factory production control**

In the manufacturing plant, the manufacturer establishes and continuously maintains a factory production control. All procedures and specifications adopted by the manufacturer are documented in a systematic manner. Purpose of factory production control is to ensure the constancy of performances of the Rock and soil anchor system SAS with prestressing steel thread bars Y1050H, diameter 17.5 to 47 mm, with regard to the essential characteristics.

The manufacturer only uses raw materials supplied with the relevant inspection documents as laid down in the control plan. The incoming raw materials are subjected to controls by the manufacturer before acceptance. Check of incoming materials includes control of inspection documents presented by the manufacturer of the raw materials.

Testing within factory production control is in accordance with the prescribed test plan. The results of factory production control are recorded and evaluated. The records are presented to the notified product certification body involved in continuous surveillance and are kept at least for ten years after the product has been placed on the market. On request, the records are presented to Österreichisches Institut für Bautechnik.

If test results are unsatisfactory, the manufacturer immediately implements measures to eliminate the defects. Products or components that are not in conformity with the requirements are removed. After elimination of the defects, the respective test – if verification is required for technical reasons – is repeated immediately.

At least once a year the manufacturer audits the manufacturers of nuts and couplers.

The basic elements of the prescribed test plan are given in Annex 21 and Annex 22.

#### **5.1.2 Declaration of performance**

The manufacturer is responsible for preparing the declaration of performance. When all the criteria of the assessment and verification of constancy of performance are met, including the certificate of constancy of performance issued by the notified product certification body, the manufacturer draws up the declaration of performance. Essential characteristics to be included in the declaration of performance for the corresponding intended use are given in Clause 3.1, Table 5. In Annex 25 and Annex 26 the combinations of essential characteristics and corresponding intended uses are listed.

### **5.2 Tasks for the notified product certification body**

#### **5.2.1 Initial inspection of the manufacturing plant and of factory production control**

The notified product certification body verifies the ability of the manufacturer for a continuous and orderly manufacturing of the Rock and soil anchor system SAS with prestressing steel thread bars Y1050H, diameter 17.5 to 47 mm, according to the European Technical Assessment. In particular, the following items are appropriately considered.

- Personnel and equipment
- Suitability of the factory production control established by the manufacturer
- Full implementation of the prescribed test plan

#### **5.2.2 Continuing surveillance, assessment, and evaluation of factory production control**

The notified product certification body visits the factory at least once a year for routine inspection. Inspection of factory production control of steel bar is twice a year. In particular the following items are appropriately considered.

- Manufacturing process including personnel and equipment







**Rock and soil anchor system SAS**  
 Prestressing steel bar Y1050H,  $\varnothing$  17.5–47 mm  
 Temporary rock and soil anchor

**Annex 1**  
 of European Technical Assessment  
**ETA-12/0601** of 21.12.2018

Rock and soil anchor system SAS – Temporary rock and soil anchor

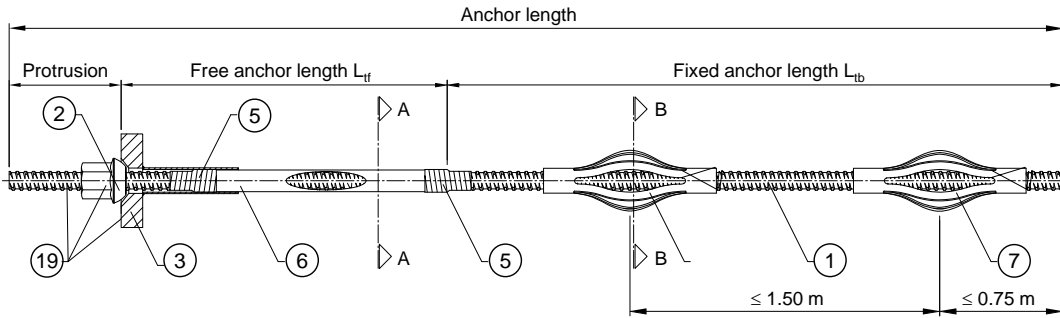

Anchor heads variants

Steel bearing

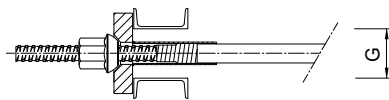

Fully concreted

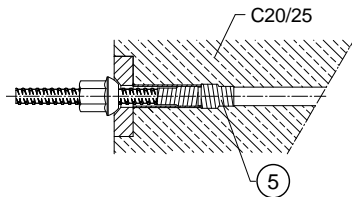

Bearing on larger borehole or distance

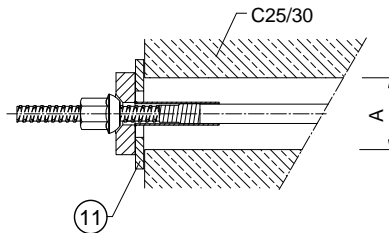

Sections

A – A, Cross section in  $L_{ff}$     B – B, Cross section in  $L_{fb}$

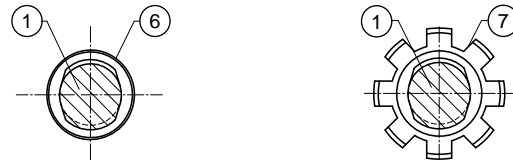

Angle compensation with tube

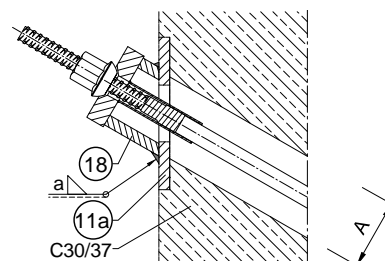

Prestressing steel bar nominal diameter $\varnothing$	Maximum G for bearing on steel	Maximum A <sup>1)</sup> for load transfer plate	Fillet weld minimum thickness	Minimum borehole diameter <sup>2)</sup>			
				at anchor head	without coupler	with coupler at $L_{ff} - L_{fb}$ <sup>3)</sup>	with coupler in $L_{ff}$
mm	mm	mm	a	mm	mm	mm	mm
17.5	80	160	3.5	55	50	60	70
26.5	90		5	65	60	75	85
32	100		6	70	65	85	95
36	130		7	70	65	90	110
40			8	90	80	95	110
47			8	100	90	110	130

- ① Prestressing steel bar
- ② Domed nut
- ③ Anchor plate with steel tube
- ⑤ Adhesive tape
- ⑥ Smooth sheathing
- ⑦ Basket spacer
- ⑪ Load transfer plate
- ⑪a Load transfer plate for angle compensation tube
- ⑱ Angle compensation tube
- ⑲ Corrosion protection coating

<sup>1)</sup> For load transfer plates to span larger distances, see Annex 6, a minimum concrete strength class according to EN 206 of  $\geq$  C25/30 for Pos. 11 and  $\geq$  C30/37 for Pos. 11a is required.  
<sup>2)</sup> The minimum borehole diameter is based on the minimum cover of grout including an injection hose  $\varnothing$  10 mm  
<sup>3)</sup> Coupler at transition free anchor length,  $L_{ff}$ , to fixed anchor length,  $L_{fb}$





**Rock and soil anchor system SAS**  
 Prestressing steel bar Y1050H,  $\varnothing$  17.5–47 mm  
 Temporary rock and soil anchor with  
 extended working life

**Annex 2**  
 of European Technical Assessment  
**ETA-12/0601** of 21.12.2018

Rock and soil anchor system SAS – Temporary rock and soil anchor with an extended working life

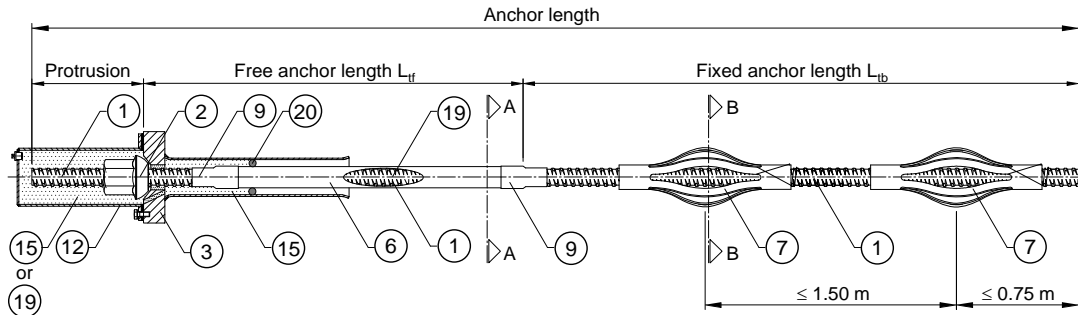

Anchor heads variants

Steel bearing

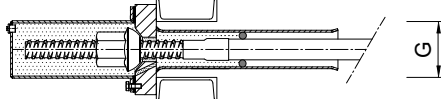

Fully concreted

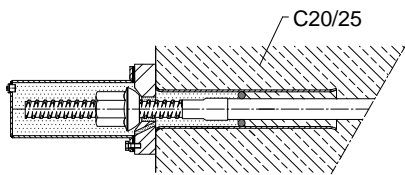

Bearing on larger borehole or distance

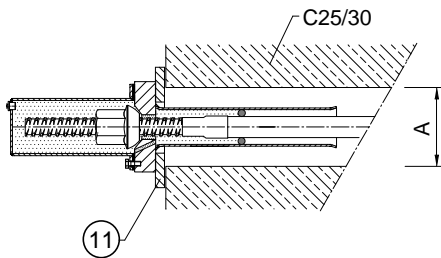

Sections

A – A, Cross section in  $L_{tf}$

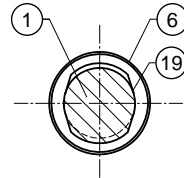

B – B, Cross section in  $L_{tb}$

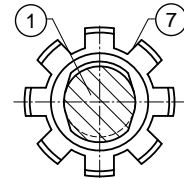

Angle compensation with tube

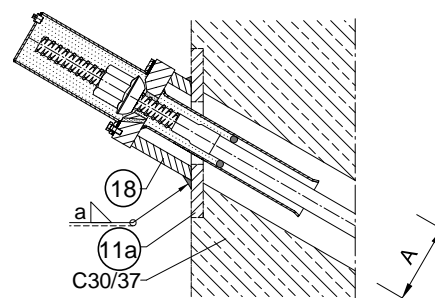

Prestressing steel bar nominal diameter $\varnothing$	Maximum G for bearing on steel G	Maximum A <sup>1)</sup> for load transfer plate A	Fillet weld minimum thickness a	Minimum borehole diameter <sup>2)</sup>			
				at anchor head	without coupler	with coupler at $L_{tf} - L_{tb}$ <sup>3)</sup>	with coupler in $L_{tf}$
mm	mm	mm	mm	mm	mm	mm	mm
17.5	80	160	3.5	80	50	60	70
26.5	90		5	80	60	75	85
32	100		6	85	65	85	95
36	130		7	95	65	90	110
40			8	95	80	95	110
47			8	120	90	110	130

- ① Prestressing steel bar
- ② Domed nut
- ③ Anchor plate with steel tube
- ⑥ Smooth sheathing
- ⑦ Basket spacer
- ⑨ Heat shrinking sleeve
- ⑪ Load transfer plate
- ⑪a Load transfer plate for angle compensation tube
- ⑫ Steel cap or plastic cap
- ⑮ Corrosion protection grease
- ⑱ Angle compensation tube
- ⑲ Corrosion protection coating
- ⑳ Sealing ring

<sup>1)</sup> For load transfer plates to span larger distances, see Annex 6, a minimum concrete strength class according to EN 206 of  $\geq$  C25/30 for Pos. 11 and  $\geq$  C30/37 for Pos. 11a is required.

<sup>2)</sup> The minimum borehole diameter is based on the minimum cover of grout including an injection hose  $\varnothing$  10 mm

<sup>3)</sup> Coupler at transition free anchor length,  $L_{tf}$ , to fixed anchor length,  $L_{tb}$



**Rock and soil anchor system SAS**  
 Prestressing steel bar Y1050H,  $\varnothing$  17.5–47 mm  
 Permanent rock and soil anchor

**Annex 3**  
 of European Technical Assessment  
**ETA-12/0601** of 21.12.2018

**Rock and soil anchor system SAS – Permanent rock and soil anchor**

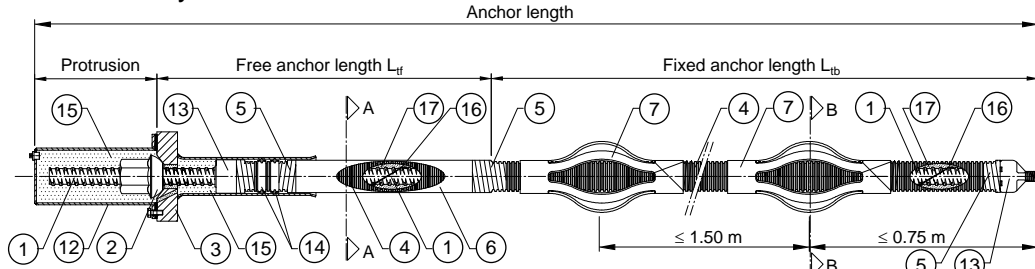

**Anchor heads variants**

**Steel bearing**

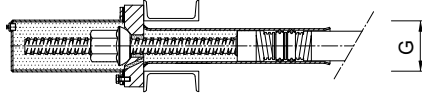

**Fully concreted**

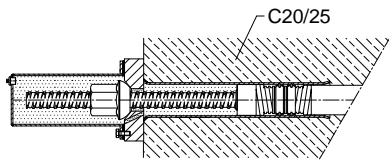

**Bearing on larger borehole or distance**

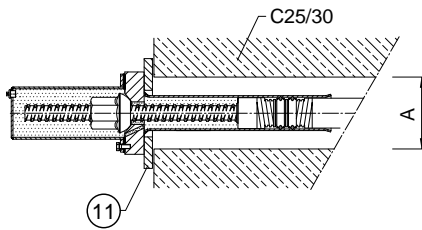

**Sections**

A – A, Cross section in  $L_{tf}$     B – B, Cross section in  $L_{tb}$

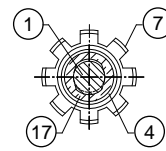
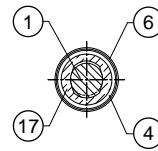

**Angle compensation with tube**

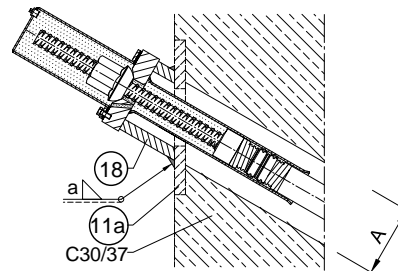

- ① Prestressing steel bar
- ② Domed nut
- ③ Anchor plate with steel tube
- ④ Corrugated sheathing
- ⑤ Adhesive tape
- ⑥ Smooth sheathing
- ⑦ Basket spacer
- ⑪ Load transfer plate
- ⑪a Load transfer plate for angle compensation tube
- ⑫ Steel cap or plastic cap
- ⑬ Injection cap or end cap
- ⑭ Profile ring
- ⑮ Corrosion protection grease
- ⑯ Inner spacer
- ⑰ Inner cement grout
- ⑱ Angle compensation tube

Prestressing steel bar nominal diameter $\varnothing$	Maximum G for bearing on steel G	Maximum A <sup>1)</sup> for load transfer plate A	Fillet weld minimum thickness a	Minimum borehole diameter <sup>2)</sup>			
				at anchor head	without coupler	with coupler at $L_{tf} - L_{tb}$ <sup>3)</sup>	with coupler in $L_{tf}$
mm	mm	mm	mm	mm	mm	mm	mm
17.5	80	160	3.5	80	70	70	85
26.5	90		5	80	70	75	85
32	100		6	85	80	85	95
36	130		7	95	85	90	110
40			8	95	85	95	110
47			8	120	100	110	130

<sup>1)</sup> For load transfer plates to span larger distances, see Annex 6, a minimum concrete strength class according to EN 206 of  $\geq$  C25/30 for Pos. 11 and  $\geq$  C30/37 for Pos. 11a is required.  
<sup>2)</sup> The minimum borehole diameter is based on the minimum cover of grout including an injection hose  $\varnothing$  10 mm  
<sup>3)</sup> Coupler at transition free anchor length,  $L_{tf}$ , to fixed anchor length,  $L_{tb}$



Max Aicher GmbH & Co. KG  
 83404 Ainring-Hammerau

**Rock and soil anchor system SAS**  
 Prestressing steel bar Y1050H,  $\varnothing$  17.5–47 mm  
 Coupling assemblies

**Annex 4**  
 of European Technical Assessment  
**ETA-12/0601** of 21.12.2018

Coupling assemblies – Temporary rock and soil anchor  
 Transition free anchor length  $L_{ff}$  – fixed anchor length  $L_{tb}$

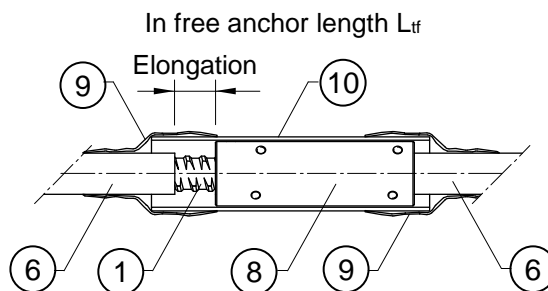
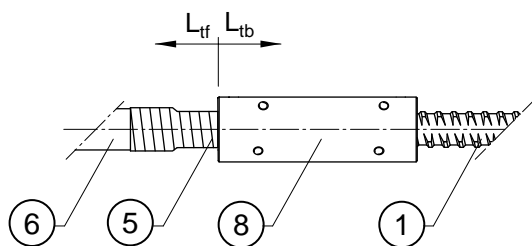

Coupling assemblies – Temporary rock and soil anchor with extended working life  
 Transition free anchor length  $L_{ff}$  – fixed anchor length  $L_{tb}$

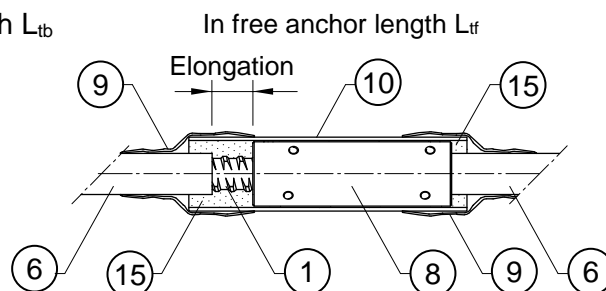
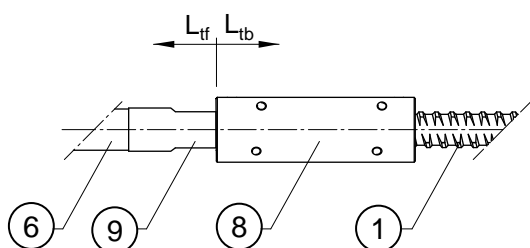

Coupling assemblies – Permanent rock and soil anchor

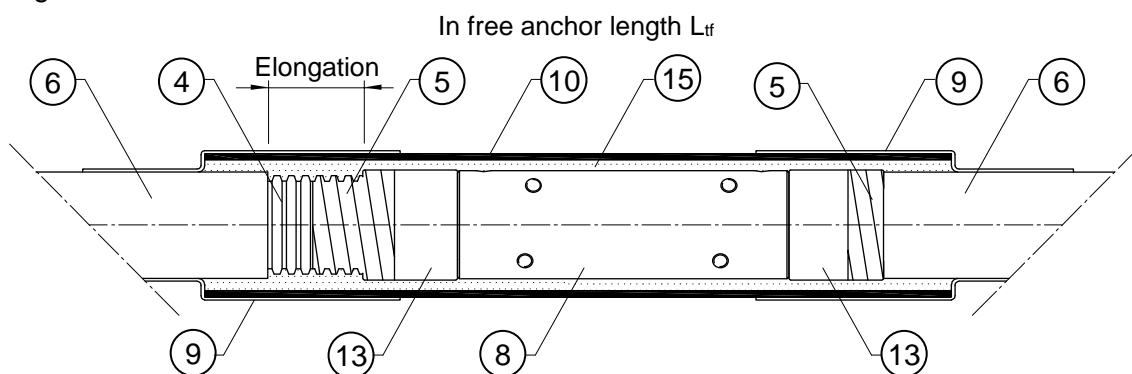

**Coupler at transition**

free anchor length,  $L_{ff}$ , to fixed anchor length,  $L_{tb}$

The coupler is protected with a double layer of heat shrinking sleeve. Overlap of heat shrinking sleeve and adjacent elements, i.e. prestressing steel bar or corrugated plastic sheathing, is at least 75 mm.

**Coupler in fixed anchor length,  $L_{tb}$**

In the fixed anchor length coupler are avoided. If a coupler is required in an exceptional case, the coupler is protected with a double layer of heat shrinking sleeve. Overlap of heat shrinking sleeve and adjacent elements, i.e. prestressing steel bar or corrugated plastic sheathing, is at least 75 mm.

- ① Prestressing steel bar
- ④ Corrugated sheathing
- ⑤ Adhesive tape
- ⑥ Smooth sheathing
- ⑧ Coupler with set screws
- ⑨ Heat shrinking sleeve
- ⑩ Coupler tube
- ⑬ Injection cap or end cap
- ⑮ Corrosion protection grease



Max Aicher GmbH & Co. KG  
 83404 Ainring-Hammerau

**Rock and soil anchor system SAS**  
 Prestressing steel bar Y1050H,  $\varnothing$  17.5–47 mm  
 Proof forces and lock-off forces

**Annex 5**  
 of European Technical Assessment  
**ETA-12/0601** of 21.12.2018

The specified proof forces and lock-off forces of the rock and soil anchor are recommended in the absent of applicable standards and regulations in force at the place of use.

Prestressing steel bar Y1050H, $R_{p0.1} = 950 \text{ N/mm}^2$ , $R_m = 1\,050 \text{ N/mm}^2$						
Prestressing steel bar nominal diameter	Characteristic force at yield strength	Characteristic maximum force	Maximum lock-off force <sup>1)</sup>	Investigation test maximum proof force <sup>2)</sup>	Suitability test maximum proof force <sup>2)</sup>	Acceptance test maximum proof force <sup>2)</sup>
$\varnothing$	$F_{p0.1}$	$F_{pk}$	—	—	—	—
mm	kN	kN	kN	kN	kN	kN
17.5	230	255	191	219 or 204	219 or 204	219 or 204
26.5	525	580	435	499 or 464	499 or 464	499 or 464
32	760	845	634	722 or 676	722 or 676	722 or 676
36	960	1 070	803	912 or 856	912 or 856	912 or 856
40	1 190	1 320	990	1 131 or 1 056	1 131 or 1 056	1 131 or 1 056
47	1 650	1 820	1 365	1 568 or 1 456	1 568 or 1 456	1 568 or 1 456

1) Maximum lock-off force according to Eurocode 2 and Eurocode 7,

$$\dots\dots\dots \text{minimum} \begin{cases} 0.75 \cdot F_{pk} \\ 0.85 \cdot F_{p0.1} \end{cases}$$

2) Maximum proof force in investigation, suitability, and acceptance test according to Eurocode 2 and

$$\text{Eurocode 7} \dots\dots\dots \begin{cases} 0.95 \cdot F_{p0.1} \\ \text{or} \\ \text{minimum} \begin{cases} 0.80 \cdot F_{pk} \\ 0.90 \cdot F_{p0.1} \end{cases} \end{cases}$$

Proof force of  $0.95 \cdot F_{p0.1}$  can only be applied, if the force in the prestressing jack can be measured to an accuracy of  $\pm 5\%$  of the final value of the proof force. Otherwise, minimum  $\begin{cases} 0.80 \cdot F_{pk} \\ 0.90 \cdot F_{p0.1} \end{cases}$  is taken.

NOTE For crack width in inner grout see Annex 9.

electronic copy



Max Aicher GmbH & Co. KG  
 83404 Ainring-Hammerau

**Rock and soil anchor system SAS**  
 Prestressing steel bar Y1050H,  $\varnothing$  17.5–47 mm

**Centre spacing and edge distance  
 Additional reinforcement**

**Annex 6**

of European Technical Assessment  
**ETA-12/0601** of 21.12.2018

**Mechanical anchorage without additional reinforcement**

- Actual concrete compressive strength at time of stressing,  $f_{cm,0, \text{cube } 150} \geq 25 \text{ N/mm}^2$
- Minimum concrete compressive strength class according to EN 206  $\geq \text{C20/25}$
- Reinforcement in the anchorage zone according to Clause 1.7.

Prestressing steel bar nominal diameter	Centre spacing	Edge distance
$\varnothing$	C	E
mm	mm	mm
17.5	200	90 + c
26.5	280	130 + c
32	340	160 + c
36	380	180 + c
40	420	200 + c
47	500	240 + c

Prestressing steel bar nominal diameter	Maximum diameter <sup>1), 2)</sup>
$\varnothing$	
mm	mm
17.5	63.5
26.5	
32	70.0
36	76.1
40	
47	101.6

c...Concrete cover of reinforcement according to standards and regulations in force at the place of use. The exposure classes according to EN 206 are considered.

<sup>1)</sup>...Maximum diameter for mechanical anchorage without and with additional reinforcement

**Mechanical anchorage with additional reinforcement – bursting reinforcement**

- Actual concrete compressive strength at time of stressing,  $f_{cm,0, \text{cube } 150} \geq 25 \text{ N/mm}^2$
- Minimum concrete compressive strength class according to EN 206  $\geq \text{C20/25}$

Prestressing steel bar nominal diameter	Anchor plate TR 2011- $\varnothing$			
	Centre spacing	Edge distance	Additional reinforcement Ribbed reinforcing steel, $R_e \geq 500 \text{ N/mm}^2$	
$\varnothing$	C	E	$n \times \varnothing / a / l$ <sup>3)</sup>	$h \times h$ <sup>4)</sup>
mm	mm	mm	- x mm / mm / mm	mm x mm
17.5	160	70 + c	5 x 10 / 30 / 20	140 x 140
26.5	240	110 + c	4 x 12 / 60 / 20	220 x 220
32	300	140 + c	5 x 12 / 60 / 20	280 x 280
36	340	160 + c	6 x 12 / 60 / 20	320 x 320
40	380	180 + c	6 x 12 / 60 / 20	360 x 360
47	440	210 + c	7 x 12 / 60 / 35	420 x 420

<sup>1)</sup> Maximum diameter for mechanical anchorage without and with additional reinforcement

<sup>2)</sup> Larger bearing distances are spanned with load transfer plates and the minimum concrete compressive strength class according to EN 206 is  $\geq \text{C25/30}$  and with angle compensation tube is  $\geq \text{C30/37}$ .

c.....Concrete cover of reinforcement according to standards and regulations in force at the place of use. The exposure classes according to EN 206 are considered.

<sup>3)</sup> n.....Number of stirrups  
 $\varnothing$ .....Nominal diameter of additional reinforcement  
 a.....Axis spacing of additional reinforcement  
 l.....Distance of first stirrup to anchor plate  
<sup>4)</sup> h.....External dimensions of stirrups

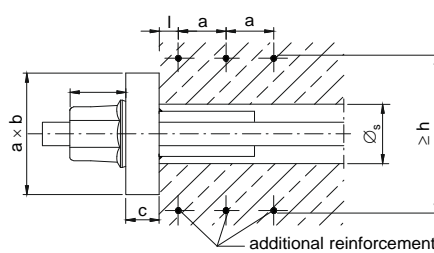
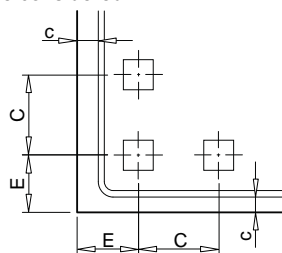



**Rock and soil anchor system SAS**  
 Prestressing steel bar Y1050H,  $\varnothing$  17.5–47 mm  
 Prestressing steel bar – Nominal  
 dimensions and mass – Rib geometry

**Annex 7**  
 of European Technical Assessment  
**ETA-12/0601** of 21.12.2018

① Prestressing steel bar

Geometry

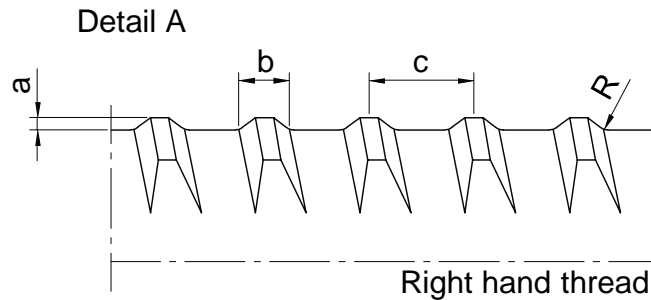
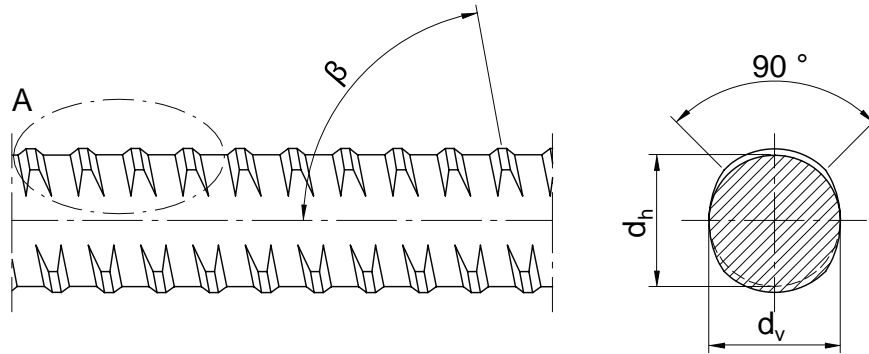

Diameter	Nominal		Core diameter		Ribs, right hand thread				
	Mass per metre <sup>1)</sup>	Cross-sectional area			Depth	Width	Pitch	Gradient	Radius
$\varnothing$ mm	M kg/m	$S_n$ mm <sup>2</sup>	$d_h$ mm	$d_v$ mm	min a mm	b mm	c mm	$\beta$ °	R mm
17.5	1.96	241	17.4	17.2	1.1	4.1	8	82.5	1.8
26.5	4.48	552	26.4	25.9	1.7	6.2	13	81.5	2.6
32	6.53	804	31.9	31.4	1.9	7.6	16	81.5	3.2
36	8.27	1 018	35.9	35.4	2.1	8.7	18	81.5	3.6
40	10.21	1 257	39.7	38.9	2.1	9.6	20	81.5	4.0
47	14.10	1 735	46.6	45.8	2.4	10.5	21	82.5	4.0

<sup>1)</sup> Nominal mass per metre, including 3.5 % of non load-bearing ribs

Tolerance to nominal mass  $\begin{cases} + 6 \% \\ - 2 \% \end{cases}$





Max Aicher GmbH & Co. KG  
83404 Ainring-Hammerau

**Rock and soil anchor system SAS**  
Prestressing steel bar Y1050H,  $\varnothing$  17.5–47 mm

Prestressing steel bar – Mechanical  
technological characteristics

**Annex 8**

of European Technical Assessment  
**ETA-12/0601** of 21.12.2018

① Prestressing steel bar

Prestressing steel bar nominal diameter $\varnothing$ mm	Characteristic	
	force at yield strength <sup>1)</sup> $F_{p0.1}$ kN	maximum force <sup>1)</sup> $F_{pk}$ kN
17.5	230	255
26.5	525	580
32	760	845
36	960	1 070
40	1 190	1 320
47	1 650	1 820

<sup>1)</sup> 5 % fractile

Characteristic yield strength <sup>1)</sup>	$R_{p0.1}$	N/mm <sup>2</sup>	950
Characteristic tensile strength <sup>1)</sup>	$R_m$	N/mm <sup>2</sup>	1 050
Elongation at maximum force $A_{gt} = A_g + \frac{R_m}{E} \cdot 100$ <sup>2)</sup>	$A_{gt}$	%	$\geq 3.5$
Constriction at break Ductile break, reduction of area after fracture	Z	%	$\geq 10$
Fatigue resistance <sup>3)</sup> at an upper stress of $\sigma_{up} = 0.7 \cdot R_{m, act}$ and up to $2.0 \cdot 10^6$ load cycles. Tested stress range for $\varnothing$ 17.5 to 32 mm $\varnothing$ 36 and 40 mm $\varnothing$ 47 mm	$2 \cdot \sigma_A$	N/mm <sup>2</sup> N/mm <sup>2</sup> N/mm <sup>2</sup>	180 137 — <sup>4)</sup>
Stress relaxation With an initial stress of $0.7 \cdot R_{m, act}$	—	%	$\leq 4$
Stress corrosion resistance Within a test series at a stress of $0.8 \cdot R_{m, act}$ $\varnothing$ 17.5 mm, duration to fracture { individual result median $\varnothing$ 26.5 mm, duration to fracture { individual result median	—	h h h h	$\geq 20$ $\geq 250$ $\geq 100$ $\geq 400$

<sup>1)</sup> 5 % fractile

<sup>2)</sup> Modulus of elasticity  $E \approx 205\,000$  N/mm<sup>2</sup>,  $A_g$  as plastic extension at maximum force

<sup>3)</sup> Fatigue resistance of prestressing steel bar without anchorage and coupler

<sup>4)</sup> For nominal diameter 47 mm fatigue resistance is not assessed.





Max Aicher GmbH & Co. KG  
 83404 Ainring-Hammerau

**Rock and soil anchor system SAS**  
 Prestressing steel bar Y1050H,  $\varnothing$  17.5–47 mm

Inner grout – Specification

**Annex 9**

of European Technical Assessment  
**ETA-12/0601** of 21.12.2018

⑰ Inner grout

Content of aggressive components	Cl <sup>-</sup> SO <sub>3</sub> <sup>2-</sup> S <sup>2-</sup>	%	≤ 0.1 ≤ 4.5 ≤ 0.01
Residue on sieve		—	≤ 0.01
Fluidity, cone	t <sub>0</sub>	s	≤ 25
	t <sub>30</sub>	s	$\left\{ \begin{array}{l} \leq 1.2 \cdot t_0 \\ \geq 0.8 \cdot t_0 \\ \leq 25 \end{array} \right.$
Fluidity, grout spread <sup>1)</sup>		—	—
Bleeding, wick-induced		%	≤ 0.3
Bleeding, inclined tube		%	≤ 0.3
Volume change		%	≥ - 1 ≤ + 5
Compressive strength		N/mm <sup>2</sup>	≥ 30
Setting time		h	≥ 3 ≤ 24
Fluid density		kg/m <sup>3</sup>	2 050
Crack width of inner grout at 60 % of R <sub>m</sub>		mm	≤ 0.1

<sup>1)</sup> Not relevant



Max Aicher GmbH & Co. KG  
 83404 Ainring-Hammerau

**Rock and soil anchor system SAS**  
 Prestressing steel bar Y1050H,  $\varnothing$  17.5–47 mm  
 Heat shrinking sleeve – Specification

**Annex 10**  
 of European Technical Assessment  
**ETA-12/0601** of 21.12.2018

⑨ Heat shrinking sleeve  
 P 7029

Characteristics	—	P7029
Thickness after shrinking	mm	$\geq 1.0$
Mass per unit area of adhesive	g/m <sup>2</sup>	$\geq 600$
Tensile strength	N/mm	$\geq 20$
Elongation at break	%	$\geq 600$
Peel strength layer to layer	N/mm	$\geq 1.5$
Peel strength to steel surface	N/mm	$\geq 1.0$
Thermal ageing resistance	$\frac{S_{100}}{S_0}, \frac{E_{100}}{E_0}$	$\begin{cases} \leq 1.25 \\ \geq 0.75 \end{cases}$
	$\frac{S_{100}}{S_{70}}, \frac{E_{100}}{E_{70}}$	$\geq 0.8$
	$\frac{P_{100}}{P_T}, \frac{A_{100}}{A_T}$	$\geq 0.75$
	$\frac{P_{100}}{P_{70}}, \frac{A_{100}}{A_{70}}$	$\geq 0.8$
Indentation resistance	Residual thickness mm	$\geq 0.6$
Impact resistance	—	C
Saponification value	$\frac{\text{mg KOH}}{\text{g}}$	15
Microbiological resistance	$\frac{S_6}{S_0}, \frac{E_6}{E_0}$	$\geq 0.8$
	$\frac{A_6}{A_T}$	$\geq 0.8$
Water absorption	%	$\leq 0.05$
Softening point of adhesive	°C	120
Oxygen stability of adhesive	min	20
Resistance to salt spray of adhesive		No corrosion
Content of aggressive components of adhesive	Cl <sup>-</sup>	$\leq 50$
	NO <sup>-3</sup>	$\leq 50$
	NO <sup>-2</sup>	$\leq 10$
	SO <sub>4</sub> <sup>-2</sup>	$\leq 50$
	S <sup>-2</sup>	$\leq 10$



Max Aicher GmbH & Co. KG  
 83404 Ainring-Hammerau

**Rock and soil anchor system SAS**  
 Prestressing steel bar Y1050H,  $\varnothing$  17.5–47 mm

Components – Domed nut, square anchor plate, welded steel tube – Dimensions

**Annex 11**  
 of European Technical Assessment  
**ETA-12/0601** of 21.12.2018

② Domed nut  
 TR 2001- $\varnothing$

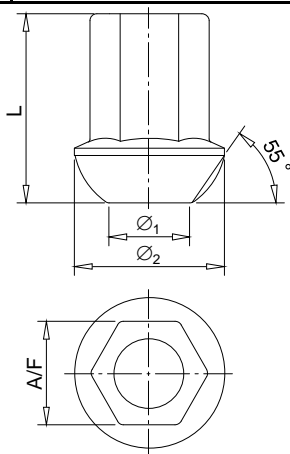

Prestressing steel bar $\varnothing$	A/F	L	$\varnothing_1$	$\varnothing_2$
mm	mm	mm	mm	mm
17.5	36	55	31	50
26.5	50	75	44	72
32	60	90	48	80
36	65	100	50	90
40	70	115	55	100
47	80	135	65	110

③ Square anchor plate with steel tube  
 Temporary rock and soil anchor  
 TR 2111- $\varnothing$

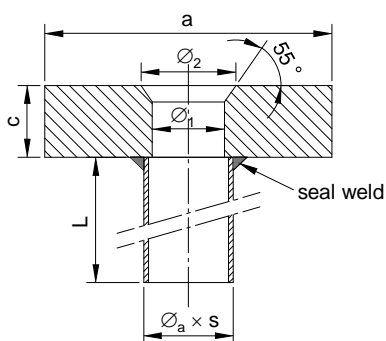

Temporary rock and soil anchor  
 with extended working life  
 Permanent rock and soil anchor  
 TR 2110- $\varnothing$

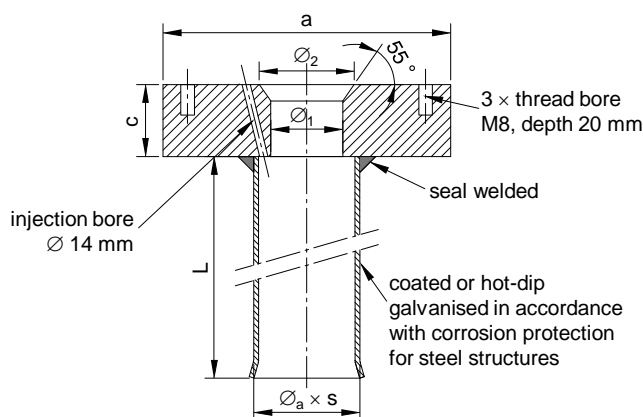

Prestressing steel bar	Anchor plate			Steel tube				
				Temporary rock and soil anchor		Temporary rock and soil anchor with extended working life Permanent rock and soil anchor <sup>1)</sup>		
$\varnothing$	a	c	$\varnothing_1$	$\varnothing_2$	$\varnothing_a \times s$	L	$\varnothing_a \times s$	L
mm	mm	mm	mm	mm	mm $\times$ mm	mm	mm $\times$ mm	mm
17.5	110	30	28	45	44.5 $\times$ 2.3	150	63.5 $\times$ 2.6	300
26.5	150	35	39	72	51.0 $\times$ 2.3		70.0 $\times$ 2.6	
32	180	40	45	82	57.0 $\times$ 2.3		76.1 $\times$ 2.6	
36	200	45	49	92	60.3 $\times$ 2.3			
40	220	45	54	100	76.0 $\times$ 2.6			
47	260	50	64	110	88.9 $\times$ 2.9		101.6 $\times$ 2.9	

<sup>1)</sup> For permanent rock and soil anchors, the wall thickness of the steel tube is to be increased by 1 mm for high corrosion load according to EN 12501-1, -2.



Max Aicher GmbH & Co. KG  
 83404 Ainring-Hammerau

**Rock and soil anchor system SAS**  
 Prestressing steel bar Y1050H,  $\varnothing$  17.5–47 mm

Components – Coupler with set screws,  
 load transfer plates – Dimensions

**Annex 12**

of European Technical Assessment  
**ETA-12/0601** of 21.12.2018

**8** Coupler with set screws  
 TR 3020- $\varnothing$

To prevent unscrewing, 3 set screws at both ends of the coupler  
 Hexagon socket set screws with flat point, EN ISO 4026

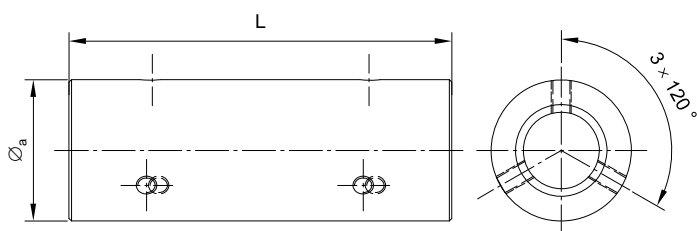

Prestressing steel bar $\varnothing$	$\varnothing_a$	L	Set screw
mm	mm	mm	mm
17.5	36	100	M 8
26.5	50	170	
32	60	200	
36	68	210	
40	70	245	M 10
47	89	280	

**11** Load transfer plate <sup>1)</sup> for large bore holes, recess tube  
 TR 2149- $\varnothing$

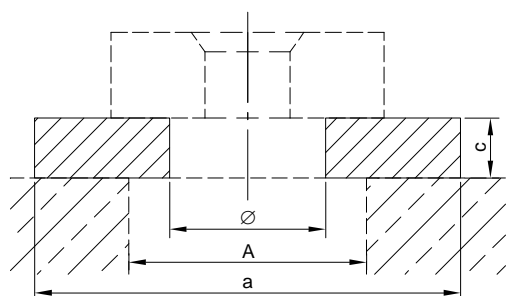

Prestressing steel bar $\varnothing$	max. $\varnothing$ A or borehole	a	c	$\varnothing$
mm	mm	mm	mm	mm
17.5	160	180	20	73
26.5		195	20	73
32		215	20	79
36		230	15	79
40		240	15	86
47		270	15	111

**11a** Load transfer plate <sup>1)</sup> for angle compensation tube  
 TR 2150- $\varnothing$

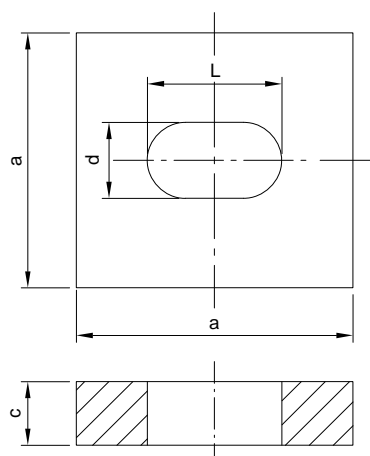

Prestressing steel bar $\varnothing$	a	c	d	L
mm	mm	mm	mm	mm
17.5	180	20	73	102
26.5	195	25	73	104
32	215	30	79	114
36	230	30	79	114
40	240	30	86	122
47	270	30	111	151

<sup>1)</sup> For permanent rock and soil anchors the exposed steel surfaces are coated or hot-dip galvanised as specified for corrosion protection of steel structures.



**Rock and soil anchor system SAS**  
 Prestressing steel bar Y1050H,  $\varnothing$  17.5–47 mm  
 Components – Angle compensation tube,  
 coupler tube – Dimensions

**Annex 13**  
 of European Technical Assessment  
**ETA-12/0601** of 21.12.2018

18 Angle compensation tube <sup>1)</sup>

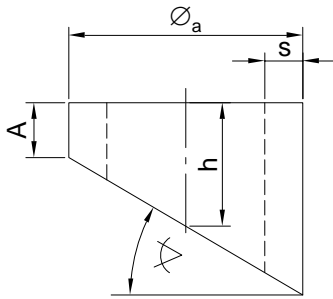

Prestressing steel bar $\varnothing$	Steel tube $\varnothing_a \times s$	A	h for an angle of					
			5 °	10 °	15 °	20 °	25 °	30 °
mm	mm × mm	mm	mm					
17.5	101.6 × 5.0	25	30	34	39	44	49	55
26.5	133.0 × 8.0	30	36	42	48	55	62	69
32	139.7 × 12.5	30	37	43	49	56	63	71
36	139.7 × 16.0	35	42	48	54	61	68	76
40	168.3 × 16.0	35	43	50	58	66	75	84
47	219.1 × 16.0	35	45	55	65	75	87	99

10 Coupler tube

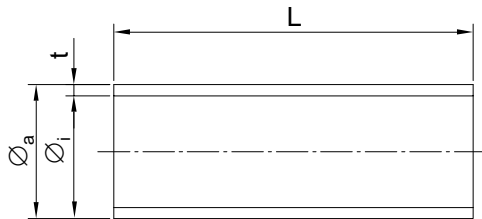

Prestressing steel bar $\varnothing$	Temporary rock and soil, Temporary rock and soil anchor with extended working life $\varnothing_a / \varnothing_i$	Permanent rock and soil anchor $\varnothing_a / \varnothing_i$	L <sup>3)</sup>	min. t
mm	mm	mm	mm	mm
17.5	50 / 44	63 / 57	450	2
26.5	63 / 57	63 / 57		
32	75 / 67.8	75 / 67.8	500	
36	90 / 84.6	90 / 84.6	600	
40	90 / 84.6	90 / 84.6		
47	110 / 105	110 / 105		

<sup>3)</sup> Elongation for a free anchor length of up to 18 m is considered

<sup>1)</sup> For permanent rock and soil anchors the exposed steel surfaces are coated or hot-dip galvanised as specified for corrosion protection of steel structures.



**Rock and soil anchor system SAS**  
 Prestressing steel bar Y1050H,  $\varnothing$  17.5–47 mm  
 Components – Steel cap – Dimensions

**Annex 14**  
 of European Technical Assessment  
**ETA-12/0601** of 21.12.2018

12 Steel cap<sup>1)</sup>  
 with accessories

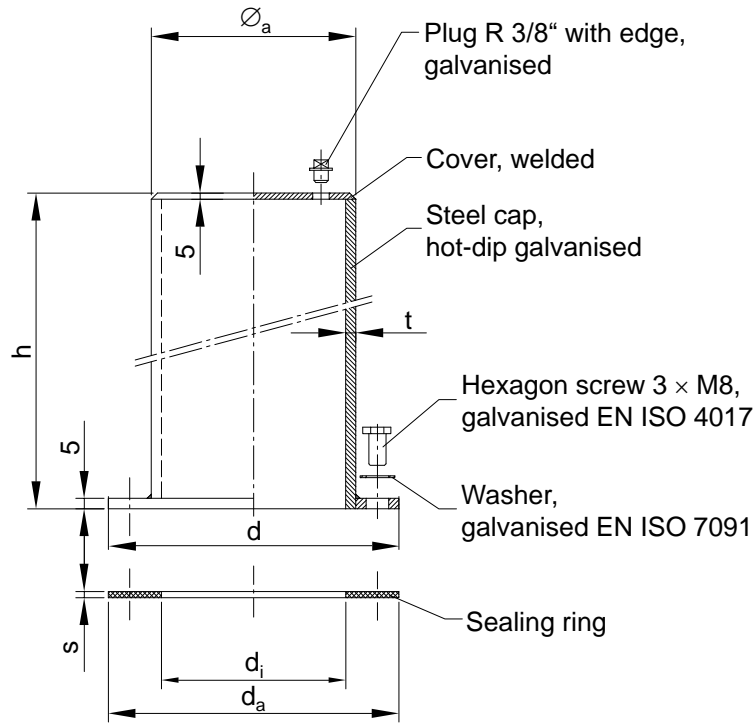

Dimensions in mm

Prestressing steel bar $\varnothing$	Steel tube $\varnothing_a \times t$	Flange $d$	Height $h$	Sealing ring $d_a \times d_i \times s$
mm	mm $\times$ mm	mm	mm	mm $\times$ mm $\times$ mm
17.5	63.5 $\times$ 3.2	110	$\geq 200$	110 $\times$ 57 $\times$ 3
26.5	88.9 $\times$ 3.2	135		135 $\times$ 82 $\times$ 3
32	95.0 $\times$ 3.2	142		142 $\times$ 88 $\times$ 3
36	101.6 $\times$ 3.2	148		148 $\times$ 94 $\times$ 3
40	114.0 $\times$ 3.6	148		148 $\times$ 107 $\times$ 3
47	127.0 $\times$ 3.6	171		171 $\times$ 120 $\times$ 3

<sup>1)</sup> For permanent rock and soil anchors the exposed steel surfaces are coated or hot-dip galvanised as specified for corrosion protection of steel structures.



**Rock and soil anchor system SAS**  
 Prestressing steel bar Y1050H,  $\varnothing$  17.5–47 mm  
 Components – Plastic cap with screw  
 socket – Dimensions

**Annex 15**  
 of European Technical Assessment  
**ETA-12/0601** of 21.12.2018

12 Plastic cap  
 with accessories

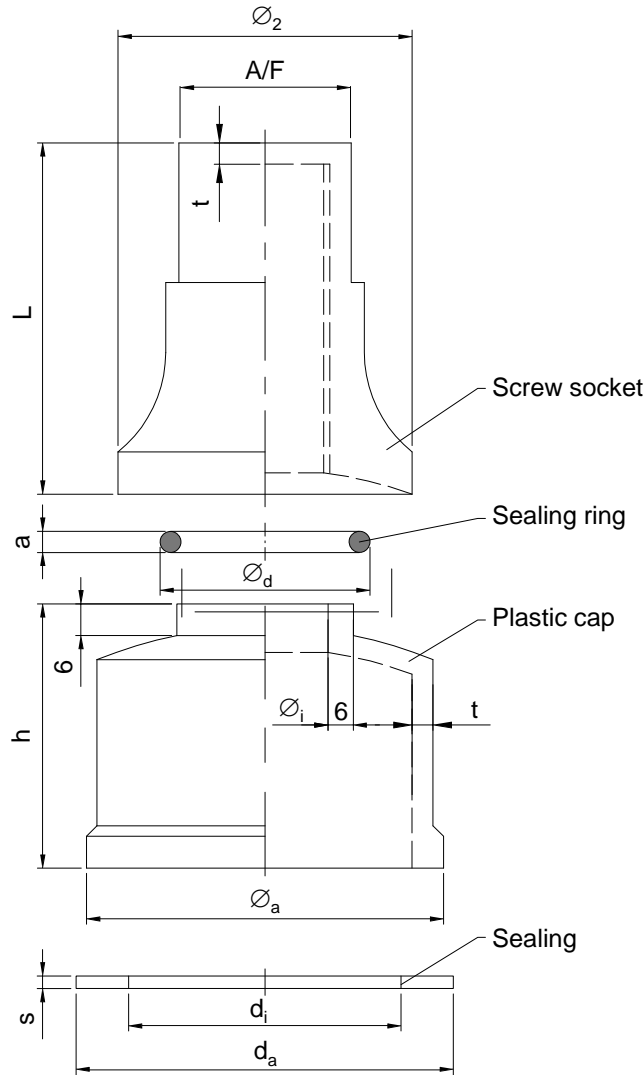

Dimensions in mm

Prestressing steel bar $\varnothing$	Plastic cap			Screw socket			Sealing ring	Sealing	
	t	$\varnothing_a \times h$	$\varnothing_1$	A/F	$\varnothing_2$	L	$\varnothing_d \times a$	$d_a / d_i$	s
mm	mm	mm $\times$ mm	mm	mm	mm	mm	mm $\times$ mm	mm / mm	mm
17.5	5	85 $\times$ 60	30	41	70	82	56 $\times$ 8	89 / 65	3
26.5–32	5	112 $\times$ 87	42	50	90	126	68 $\times$ 8	115 / 85	3
36–40	5	132 $\times$ 105	58	70	110	154	84 $\times$ 8	135 / 105	3
47	5	183 $\times$ 125	72	80	130	175	98 $\times$ 8	186 / 156	3





Max Aicher GmbH & Co. KG  
 83404 Ainring-Hammerau

**Rock and soil anchor system SAS**  
 Prestressing steel bar Y1050H,  $\varnothing$  17.5–47 mm

Components – Corrugated plastic sheathing,  
 heat shrinking sleeve – Dimensions

**Annex 16**

of European Technical Assessment  
**ETA-12/0601** of 21.12.2018

④ Corrugated sheathing

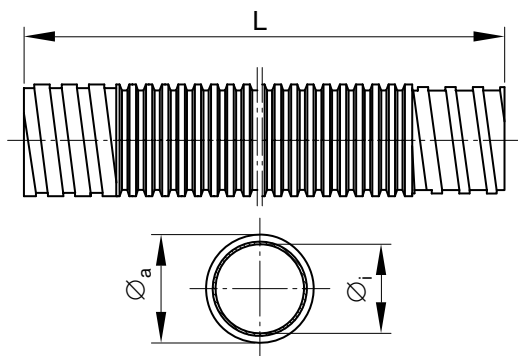

Prestressing steel bar $\varnothing$	Dimensions <sup>1)</sup>	
	$\varnothing_a / \varnothing_i$	min. t
mm	mm / mm	mm
17.5	50 / 43	1.0
26.5		
32	56 / 49	
36	65 / 57	
40		
47	80 / 71	

<sup>1)</sup> Length as required

⑨ Heat shrinking sleeve  
 P 7029

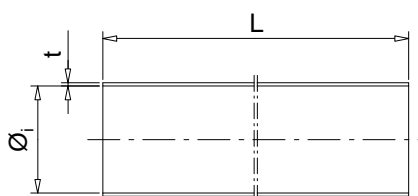

Heat shrinking sleeve	$\varnothing_i$ before shrinking	min t after shrinking
—	mm	mm
P7029-P40/15S	40	1.0
P7029-P50/20S	50	
P7029-P70/25S	70	
P7029-P90/30S	90	
P7029-P120/40S	120	
P7029-P170/80S	170	

Length of heat shrinking sleeve, L, as required. Overlap of adjacent parts of the rock and soil anchor is ensured.



Max Aicher GmbH & Co. KG  
 83404 Ainring-Hammerau

**Rock and soil anchor system SAS**  
 Prestressing steel bar Y1050H,  $\varnothing$  17.5–47 mm

Components – Smooth sheathing –  
 Dimensions

**Annex 17**  
 of European Technical Assessment  
**ETA-12/0601** of 21.12.2018

- ⑥ Smooth sheathing  
 Temporary rock and soil anchor  
 Temporary rock and soil anchor with extended working life

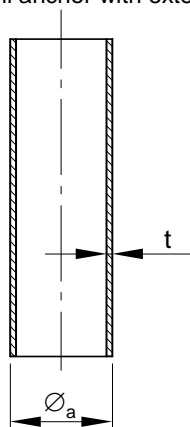

Prestressing steel bar $\varnothing$	Dimensions <sup>2)</sup>	
	$\varnothing_a$	t
mm	mm	mm
17.5	35	2.0
26.5	41	
32	46	
36	50	2.0 / 3.6
40	63	
47	75	4.3

<sup>2)</sup> Length as required

Permanent rock and soil anchor

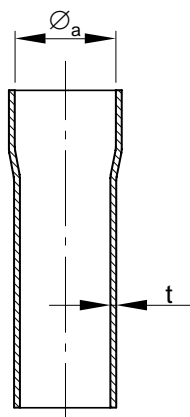

Prestressing steel bar $\varnothing$	Dimensions <sup>3)</sup>	
	$\varnothing_a$	min. t
mm	mm	mm
17.5	54.2	1.5
26.5		
32	60.1	
36	70.1	
40		
47	84.9	

<sup>3)</sup> Length as required



Max Aicher GmbH & Co. KG  
 83404 Ainring-Hammerau

**Rock and soil anchor system SAS**  
 Prestressing steel bar Y1050H,  $\varnothing$  17.5–47 mm

Components – Basket spacer, profile ring,  
 sealing ring – Dimensions

**Annex 18**

of European Technical Assessment  
**ETA-12/0601** of 21.12.2018

7 Basket spacer

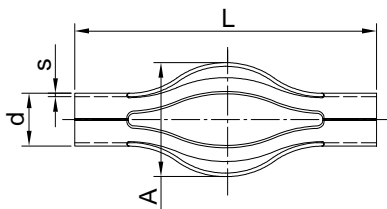

Prestressing steel bar $\varnothing$	Temporary rock and soil anchor, Temporary rock and soil anchor with extended working life			Permanent rock and soil anchor		
	d × s	A	L	d × s	A	L
mm	mm × mm	mm	mm	mm × mm	mm	mm
17.5	20 × 1.5	> 70	150 to 175	55 × 3.0	> 100	250 to 290
26.5	32 × 1.9					
32	40 × 3.0	> 90	250 to 290	63 × 3.0	> 110	
36				75 × 3.6	> 115	
40	50 × 3.0	> 100	250 to 290	90 × 2.7	> 140	
47						

14 Profile ring

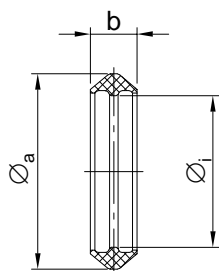

Prestressing steel bar $\varnothing$	$\varnothing_a$	$\varnothing_i$	b
mm	mm	mm	mm
17.5	58.8	45.5	14
26.5			
32	65.0	49.5	20
36	71.5	58.0	20
40			
47	96.0	75.0	23

20 Sealing ring

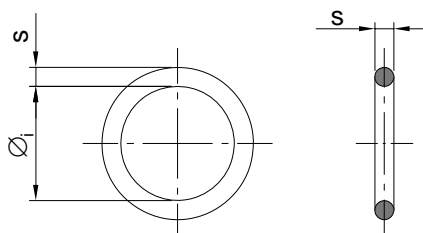

Prestressing steel bar $\varnothing$	$\varnothing_i$	s
mm	mm	mm
17.5	33	15
26.5	39	12
32	44	12
36	48	15
40	61	8
47	73	15



Max Aicher GmbH & Co. KG  
 83404 Ainring-Hammerau

**Rock and soil anchor system SAS**  
 Prestressing steel bar Y1050H,  $\varnothing$  17.5–47 mm

Components – Plastic cord, mat spacer,  
 injection and end cap – Dimensions

**Annex 19**

of European Technical Assessment  
**ETA-12/0601** of 21.12.2018

① Inner spacer  
 PE cord, pitch  $\leq 0.5$  m



Prestressing steel bar $\varnothing$	PE cord min. $\varnothing$
mm	mm
17.5	6
26.5	
32	
36	
40	
47	

Mat spacer  
 Distance  $\leq 1.0$  m

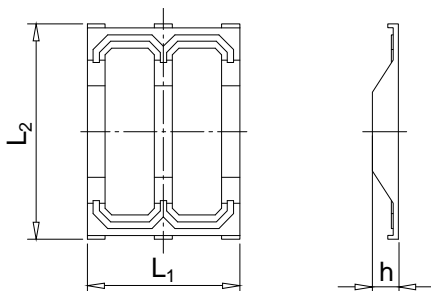

Prestressing steel bar $\varnothing$	Dimensions			Number of ribs
	h	L <sub>1</sub>	L <sub>2</sub>	
mm	mm	mm	mm	—
36	6	112	124	3
40	6	112	124	3
47	8	132	124	3

② Injection cap and end cap

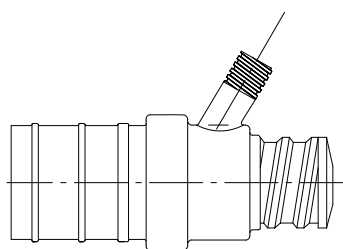

Alternative cap

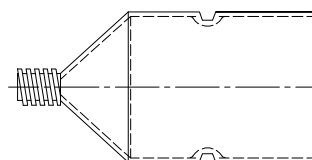



Max Aicher GmbH & Co. KG  
 83404 Ainring-Hammerau

**Rock and soil anchor system SAS**  
 Prestressing steel bar Y1050H,  $\varnothing$  17.5–47 mm

Material specifications

**Annex 20**  
 of European Technical Assessment  
**ETA-12/0601** of 21.12.2018

Component	Standard / Specification
Prestressing steel bar	Annexes 7 and 8
Domed anchor nut, $\varnothing$ 17.5, 26.5, 32, 36 mm	EN 10025
Domed anchor nut, $\varnothing$ 40, 47 mm	EN 10293
Solid plate, square	EN 10025
Steel tube	EN 10216-1 EN 10217-1
Coupler, $\varnothing$ 17.5, 26.5, 32, 36 mm	EN 10083-2
Coupler, $\varnothing$ 40, 47 mm	EN 10293
Load transfer plate	EN 10025
Angle compensation tube	EN 10210
Coupler tube	EN ISO 1163-1 EN ISO 17855-1
Steel cap	EN 10025
Corrugated sheathing Smooth sheathing Plastic cap Injection cap End cap PE cord Mat spacer	EN ISO 17855-1
Basket spacer	EN ISO 1163-1
Sealing ring Toroidal sealing ring Profile ring	Neoprene
Sealing ring Toroidal sealing ring Profile ring	Cellular rubber
Additional reinforcement	Ribbed reinforcing steel, $R_e \geq 500 \text{ N/mm}^2$
Heat shrinking sleeve	Annex 10
Inner grout	Annex 9



Max Aicher GmbH & Co. KG  
 83404 Ainring-Hammerau

**Rock and soil anchor system SAS**  
 Prestressing steel bar Y1050H, Ø 17.5–47 mm

**Contents of the prescribed test plan**

**Annex 21**  
 of European Technical Assessment  
**ETA-12/0601** of 21.12.2018

Subject / type of control	Test of control method	Criteria, if any	Minimum number of samples <sup>1)</sup>	Minimum frequency of control	
Anchorage, Coupling assembly	Static load test on anchorage and coupling assembly	2)	0.2 % <sup>3), 4)</sup> ≥ 2 <sup>4)</sup>	Per year	
	Resistance to fatigue of anchorage and coupling assembly	2)	1 <sup>4)</sup>	Per year	
Prestressing steel bar	Mass per metre, cross-sectional area, surface geometry	2)	≥ 1 <sup>5)</sup> ≥ 3 <sup>6)</sup>	Continuous	
	Strength characteristics <sup>7)</sup> Elongation at maximum force <sup>7)</sup> Constriction at break	2)	≥ 1 <sup>5)</sup> ≥ 3 <sup>6)</sup>	Continuous	
	Visual inspection <sup>8)</sup>	2)	100 %	Continuous	
	Traceability	full			
Domed anchor nut, Coupler	Dimensions	2)	5 % <sup>9), 10)</sup> ≥ 2 <sup>9), 10)</sup>	Continuous	
	Strength <sup>11)</sup>	2)	0.5 % <sup>9)</sup> ≥ 2 <sup>9)</sup>	Continuous	
	Material	Checking <sup>12)</sup>	2)	100 %	Continuous
	Visual inspection <sup>8)</sup>	2)	100 %	Continuous	
	Inspection of all components manufacturer by the manufacturer of the kit	1 per year			
Traceability	full				
Simple square anchor plate	Dimensions	2)	3 % <sup>9), 10)</sup> ≥ 2 <sup>9), 10)</sup>	Continuous	
	Material	Checking <sup>13)</sup>	2)	100 %	Continuous
	Visual inspection <sup>8)</sup>	2)	100 %	Continuous	
	Traceability	full			

- 1) For two specified numbers of samples, the higher number applies.
- 2) Conformity with the specifications of the item
- 3) Percentage of produced anchorages or coupling assemblies per nominal prestressing steel bar diameter. After 5 years of successful testing, the frequency may be reduced to 0.1 %.
- 4) For at least 1 nominal prestressing steel bar diameter. In case of a production of less than 20 anchorages or coupling assemblies of 1 nominal prestressing steel bar diameter per year, testing that nominal prestressing steel bar diameter is not required. However, all nominal prestressing steel bar diameters shall be tested within 5 years.
- 5) Per nominal prestressing steel bar diameter and 15 to
- 6) Per nominal prestressing steel bar diameter and heat
- 7) Assessment of long-term quality level according to prEN 10138-1, Clause 8.3.2.3.
- 8) Successful visual inspection does not need to be documented.
- 9) Percentage of produced component or minimum number of specimens per nominal prestressing steel bar diameter and batch of component
- 10) In case of a continuous manufacture without retooling of at least 1 000 parts, the frequency may be reduced to 1 % with at least 1 specimen per shift. The stability of the process of the continuous manufacture is verified.
- 11) Strength determined by means of hardness
- 12) Inspection certificate type "3.1" according to EN 10204
- 13) Test report type "2.2" according to EN 10204

Traceability full Full traceability of each component to its raw material.  
 Material Defined according to technical specification deposited by the supplier  
 Dimensions Measuring of all the dimensions and angles according to the specification given in the test plan  
 Visual inspection Main dimensions, gauge testing, correct marking or labelling, appropriate performance, surface, corrosion, according to the component's specification



Max Aicher GmbH & Co. KG  
 83404 Ainring-Hammerau

**Rock and soil anchor system SAS**  
 Prestressing steel bar Y1050H,  $\varnothing$  17.5–47 mm

**Contents of the prescribed test plan**

**Annex 22**

of European Technical Assessment  
**ETA-12/0601** of 21.12.2018

Subject / type of control		Test of control method	Criteria, if any	Minimum number of samples <sup>1)</sup>	Minimum frequency of control
Inner grout	Characteristics	EN 445	<sup>2)</sup>	EN 446	EN 446
	Traceability	full			
Heat shrinking sleeve	Dimensions	Testing	<sup>2)</sup>	0.5 % <sup>3)</sup> ≥ 1 <sup>3)</sup>	Continuous
	Material	Checking <sup>4)</sup>	<sup>2)</sup>	100 %	Continuous
	Thickness after shrinking	Testing	<sup>2)</sup>	0.5 % <sup>3)</sup> ≥ 1 <sup>3)</sup>	Continuous
	Bond to steel surface	Testing <sup>5)</sup>	<sup>6)</sup>	0.5 % <sup>3)</sup> ≥ 1 <sup>3)</sup>	Continuous
	Traceability	full			
Corrugated sheathing	Dimensions	Testing	<sup>2)</sup>	0.1 % <sup>7), 8)</sup> ≥ 2 <sup>7), 8)</sup>	Continuous
	Material	Checking <sup>9)</sup>	<sup>2)</sup>	100 %	Continuous
	Visual inspection <sup>10)</sup>	Checking	<sup>2)</sup>	100 %	Continuous
	Traceability	full			

- <sup>1)</sup> For two specified numbers of samples, the higher number applies.
- <sup>2)</sup> Conformity with the specifications of the item
- <sup>3)</sup> Percentage or minimum number for at least 1 size of heat shrinking sleeve per year. All sizes of heat shrinking sleeve shall be tested within 5 years.
- <sup>4)</sup> Test report type “2.2” according to EN 10204
- <sup>5)</sup> Detailed visual inspection of work samples regarding all-over adherence to steel surface, entrapped air, and bond defects
- <sup>6)</sup> Applied heat shrinking sleeve with all-over adherence to steel surface, free of entrapped air, and free of bond defects
- <sup>7)</sup> Percentage or minimum number per nominal diameter of corrugated sheathing
- <sup>8)</sup> Per nominal diameter of corrugated sheathing. In case of less than 20 applications of a nominal diameter of corrugated sheathing per year, testing that nominal diameter of corrugated sheathing is not required. However, all nominal diameters of corrugated sheathing shall be tested within 5 years.
- <sup>9)</sup> Inspection certificate type “3.1” according to EN 10204
- <sup>10)</sup> Successful visual inspection does not need to be documented.

Traceability	full	Full traceability of each component to its raw material.
Material		Defined according to technical specification deposited by the supplier
Dimensions		Measuring of all the dimensions and angles according to the specification given in the test plan
Visual inspection		Main dimensions, correct marking or labelling, appropriate performance, surface, porosities, blisters, according to the component's specification





Max Aicher GmbH & Co. KG  
83404 Ainring-Hammerau

**Rock and soil anchor system SAS**  
Prestressing steel bar Y1050H,  $\varnothing$  17.5–47 mm

Audit testing

**Annex 23**  
of European Technical Assessment  
**ETA-12/0601** of 21.12.2018

Subject / type of control		Test of control method	Criteria, if any	Minimum number of samples <sup>1)</sup>	Minimum frequency of control
Anchorage, Coupling assembly	Single element tensile test	EAD 160004-00-0301, Annex C.7			Once per 5 years
Prestressing steel bar	Mass per metre, Cross-sectional area, Surface geometry, Strength characteristics, Elongation at maximum force, Modulus of elasticity, Constriction at break, Visual inspection	Testing	<sup>2)</sup>	8 <sup>3), 4)</sup>	4 per year
	Resistance to fatigue	Testing	<sup>2)</sup>	1 <sup>3)</sup>	4 per year
	Stress relaxation	Testing	<sup>2)</sup>	1 <sup>3)</sup>	4 per year
	Stress corrosion resistance	Testing	<sup>2)</sup>	1 series <sup>3)</sup>	4 per year
Domed anchor nut, Coupler	Dimensions	Testing	<sup>2)</sup>	1 <sup>5)</sup>	Each inspection <sup>6)</sup>
	Material	Testing / Checking	<sup>2)</sup>	2 <sup>5)</sup>	Each inspection <sup>6)</sup>
	Visual inspection	Checking	<sup>2)</sup>	5 <sup>7)</sup>	Each inspection <sup>6)</sup>
Simple square anchor plate	Dimensions	Testing	<sup>2)</sup>	1 <sup>5)</sup>	Each inspection <sup>6)</sup>
	Material	Testing / Checking	<sup>2)</sup>	1 <sup>5)</sup>	Each inspection <sup>6)</sup>
	Visual inspection	Checking	<sup>2)</sup>	1 <sup>7)</sup>	Each inspection <sup>6)</sup>
Inner grout		EN 447	<sup>2)</sup>	EN 447	Once per year <sup>6)</sup>
Corrugated sheathing	Material	Testing / Checking	<sup>2)</sup>	1 <sup>8)</sup>	Each inspection <sup>6)</sup>
	Dimensions	Testing	<sup>2)</sup>	3 <sup>9)</sup>	Each inspection <sup>6)</sup>

- 1) All samples are taken at random and are clearly identified.
  - 2) Conformity with the specifications of the item
  - 3) One nominal prestressing steel bar diameter. The nominal prestressing steel bar diameter alternates from sampling to sampling. All nominal prestressing steel bar diameters shall be sampled within 5 years.
  - 4) After 5 years of successful testing, the number of samples may be reduced to 5.
  - 5) Per kind of component. One nominal prestressing steel bar diameter is sampled. All nominal diameters shall be sampled within 5 years.
  - 6) Inspection of kit manufacturer
  - 7) Each kind of component for all nominal prestressing steel bar diameters
  - 8) 1 nominal diameter of corrugated sheathing, all nominal diameters of corrugated sheathing shall be tested within 5 years.
  - 9) All nominal diameters of corrugated sheathing. Number per nominal diameter of corrugated sheathing
- Material Defined according to technical specification deposited by the ETA holder at the Notified body  
Dimension Measuring of all the dimensions and angles according to the specification given in the test plan  
Visual inspection Main dimensions, gauge testing, correct marking or labelling, appropriate performance, surface, corrosion according to the component's specification

electronic copy



Max Aicher GmbH & Co. KG  
83404 Ainring-Hammerau

**Rock and soil anchor system SAS**  
Prestressing steel bar Y1050H,  $\varnothing$  17.5–47 mm

Audit testing

**Annex 24**

of European Technical Assessment  
**ETA-12/0601** of 21.12.2018

Subject / type of control		Test of control method	Criteria, if any	Minimum number of samples <sup>1)</sup>	Minimum frequency of control
Heat shrinking sleeve	Dimensions (thickness, diameter or size)	Testing	2)	1 <sup>3)</sup>	Once per year <sup>4)</sup>
	Thickness after shrinking	Testing	2)	1 <sup>3)</sup>	
	Mass per unit area of adhesive	Testing	2)	1 <sup>3)</sup>	
	Tensile strength	Testing	2)	1 <sup>3)</sup>	
	Elongation at break	Testing	2)	1 <sup>3)</sup>	
	Peel strength to steel surface	Testing	2)	1 <sup>3)</sup>	
	Bond to steel surface	Testing	5)	2 <sup>6)</sup>	
	Chemical composition of adhesive	Testing	2)	1 <sup>3)</sup>	
	Conformity to relevant standard	Checking	2), 7)	100 %	
	Peel strength layer to layer	Testing	2)	2 <sup>6)</sup>	Once every 5 years <sup>4)</sup>
	Thermal aging resistance	Testing	2)	2 <sup>6)</sup>	
	Indentation resistance	Testing	2)	2 <sup>6)</sup>	
	Impact resistance	Testing	2)	2 <sup>6)</sup>	
	Saponification value	Testing	2)	2 <sup>6)</sup>	Once per year <sup>4)</sup>
	Chemical signature of the adhesive	Testing <sup>8)</sup>	2)	1 <sup>3)</sup>	

- 1) All samples are taken at random and are clearly identified.
- 2) According to the specification of the heat shrinking sleeve or adhesive
- 3) 1 size of heat shrinking sleeve, all sizes of heat shrinking sleeve shall be tested within 5 years. Sampling for peel strength is appropriate to the test procedure.
- 4) Inspection of kit manufacturer
- 5) Visual inspection of applied heat shrinking sleeve regarding all-over adherence to steel surface, free of entrapped air and bond defects
- 6) Samples from 2 sizes of heat shrinking sleeve
- 7) Test report type "2.2" according to EN 10204
- 8) Determination of infra-red spectrum according to DIN 51451.  
This method is applied to identify that the product is the same as the one tested during the assessment of the essential characteristics of the product by the TAB



Max Aicher GmbH & Co. KG  
 83404 Ainring-Hammerau

**Rock and soil anchor system SAS**  
 Prestressing steel bar Y1050H,  $\varnothing$  17.5–47 mm

Essential characteristics for the intended  
 uses

**Annex 25**

of European Technical Assessment  
**ETA-12/0601** of 21.12.2018

No <sup>1)</sup>	Essential characteristic <sup>1)</sup>	Product and intended use Line No according to Clause 2.1, Table 2		
		1	2	3
<b>Basic requirement for construction works 1: Mechanical resistance and stability</b>				
1	Resistance to static load of anchorages and coupling assemblies	+	+	+
2	Resistance to fatigue of anchorages and coupling assemblies	+	+	+
3	Load transfer to the structure	+	+	+
4	Corrosion protection of temporary anchor	+	—	—
5	Corrosion protection of temporary anchor with extended working life	—	+	—
6	Corrosion protection of permanent anchor	—	—	+
7	Transition anchorage to free length of temporary anchor	+	—	—
8	Transition anchorage to free length of temporary anchor with extended working life	—	+	—
9	Transition anchorage to free length of permanent anchor	—	—	+
10	Transition anchorage to free length – Tightness	+	+	+
11	Crack width in inner grout	—	—	+
<b>Prestressing steel bar</b>				
12	Cross-sectional area	+	+	+
13	Mass per metre	+	+	+
14	Surface geometry	+	+	+
15	Strength characteristics	+	+	+
16	Modulus of elasticity	+	+	+
17	Elongation at maximum force	+	+	+
18	Resistance to fatigue	+	+	+
19	Stress relaxation	+	+	+
20	Constriction at break	+	+	+
21	Stress corrosion resistance	+	+	+
<b>Nuts, anchor pieces, couplers, and anchor plates</b>				
22	Shape	+	+	+
23	Dimensions	+	+	+
24	Material	+	+	+
25	Hardness	+	+	+
<b>Inner grout</b>				
26	Content of aggressive components	—	—	+
27	Residue on sieve	—	—	+
28	Fluidity, cone	—	—	+
29	Fluidity, grout spread	—	—	+
30	Bleeding, wick-induced	—	—	+
31	Bleeding, inclined tube	—	—	+
32	Volume change	—	—	+

electronic copy



Max Aicher GmbH & Co. KG  
 83404 Ainring-Hammerau

**Rock and soil anchor system SAS**  
 Prestressing steel bar Y1050H,  $\varnothing$  17.5–47 mm

Essential characteristics for the intended  
 uses

**Annex 26**

of European Technical Assessment  
**ETA-12/0601** of 21.12.2018

No <sup>1)</sup>	Essential characteristic <sup>1)</sup>	Product and intended use Line No according to Clause 2.1, Table 2		
		1	2	3
<b>Basic requirement for construction works 1: Mechanical resistance and stability</b>				
Inner grout				
33	Compressive strength	—	—	+
34	Setting time	—	—	+
35	Fluid density	—	—	+
Heat shrinking sleeve				
36	Thickness after shrinking	—	—	+
37	Mass per unit area of adhesive	—	—	+
38	Tensile strength	—	—	+
39	Elongation at break	—	—	+
40	Peel strength layer to layer	—	—	+
41	Peel strength to steel surface	—	—	+
42	Thermal ageing resistance	—	—	+
43	Indentation resistance	—	—	+
44	Impact resistance	—	—	+
45	Saponification value	—	—	+
46	Microbiological resistance	—	—	+
47	Water absorption	—	—	+
48	Softening point of adhesive	—	—	+
49	Oxygen stability of adhesive	—	—	+
50	Resistance to salt spray of adhesive	—	—	+
51	Content of aggressive components of adhesive	—	—	+
Corrugated plastic sheathing				
52	Shape	—	—	+
53	Dimensions	—	—	+
54	Material	—	—	+

**Key**

+..... Essential characteristic relevant for the intended use

—..... Essential characteristic not relevant for the intended use

For combinations of intended uses, the essential characteristics of all intended uses composing the combination are relevant.

<sup>1)</sup> Line numbers and essential characteristics correspond to Clause 3.1, Table 5.

electronic copy

 <p>Max Aicher GmbH &amp; Co. KG 83404 Ainring-Hammerau</p>	<p><b>Rock and soil anchor system SAS</b>  Prestressing steel bar Y1050H, Ø 17.5–47 mm</p> <p>Reference documents</p>	<p><b>Annex 27</b>  of European Technical Assessment  <b>ETA-12/0601</b> of 21.12.2018</p>
<p>EAD 160004-00-0301  EAD 160045-00-0102</p> <p>EN 206+A1, 11.2016  EN 445, 10.2007  EN 446, 10.2007  EN 447, 10.2007  EN 1537, 07.2013  EN 1992-1-1, 2004  EN 1992-1-1/AC, 2008  EN 1992-1-1/AC, 2010  EN 1992-1-1/A1, 2014</p> <p>Eurocode 0  Eurocode 2  Eurocode 3  Eurocode 7</p> <p>EN 10025-series, 11.2004  EN 10083-2, 08.2006</p> <p>EN 10204, 10.2004  EN 10210-series, 04.2006</p> <p>EN 10216-1, 12.2013</p> <p>EN 10217-1+A1, 01.2005</p> <p>EN 10293, 01.2015  EN 12501-1, 04.2003  EN 12501-2, 04.2003</p> <p>EN ISO 1163-1, 1999</p> <p>EN ISO 1461, 05.2009</p>	<p>Post-Tensioning Kits for Prestressing of Structures  Kit for rock and soil anchors – Kit with Prestressing steel bars</p> <p>Concrete – Specification, performance, production and conformity  Grout for prestressing tendons – Test methods  Grout for prestressing tendons – Grouting procedures  Grout for prestressing tendons – Basic requirements  Execution of special geotechnical works – Ground anchors  Eurocode 2 – Design of concrete structures – Part 1-1: General rules and rules for buildings</p> <p>Eurocode 0 – Basis of structural design  Eurocode 2 – Design of concrete structures  Eurocode 3 – Design of steel structures  Eurocode 7 – Geotechnical design</p> <p>Hot rolled products of structural steels – Series  Steels for quenching and tempering – Part 2: Technical delivery conditions for non alloy steels</p> <p>Metallic products – Types of inspection documents  Hot finished structural hollow sections of non-alloy and fine grain steels – Series  Seamless steel tubes for pressure purposes – Technical delivery conditions – Part 1: Non-alloy steel tubes with specified room temperature properties  Welded steel tubes for pressure purposes – Technical delivery conditions – Part 1: Non-alloy steel tubes with specified room temperature properties</p> <p>Steel castings – Steel castings for general engineering uses  Protection of metallic materials against corrosion – Corrosion likelihood in soil – Part 1: General  Protection of metallic materials against corrosion – Corrosion likelihood in soil – Part 2: Low alloyed and non alloyed ferrous materials  Plastics – Unplasticized poly(vinyl chloride) (PVC-U) moulding and extrusion materials – Part 1: Designation system and basis for specifications  Hot dip galvanized coatings on fabricated iron and steel articles – Specifications and test methods</p>	

electronic copy

 <p>Max Aicher GmbH &amp; Co. KG 83404 Ainring-Hammerau</p>	<p><b>Rock and soil anchor system SAS</b>                  Prestressing steel bar Y1050H, <math>\varnothing</math> 17.5–47 mm</p> <p>Reference documents</p>	<p><b>Annex 28</b>                  of European Technical Assessment  <b>ETA-12/0601</b> of 21.12.2018</p>
<p>EN ISO 4017, 06.2014                  EN ISO 4026, 05.2004                  EN ISO 7091, 06.2000                  EN ISO 12944-5, 09.2007                  EN ISO 17855-1, 11.2014                  prEN 10138-1, 08.2009                  prEN 10138-4, 08.2009                  DIN 51451, 09.2004                  98/456/EC                  305/2011                  568/2014</p>	<p>Fasteners – Hexagon head screws – Product grades A and B                  Hexagon socket set screws with flat point                  Plain washers – Normal series – Product grade C                  Paints and varnishes – Corrosion protection of steel structures by protective paint systems – Part 5: Protective paint systems                  Plastics – Polyethylene (PE) moulding and extrusion materials – Part 1: Designation system and basis for specifications                  Prestressing steels – Part 1: General requirements                  Prestressing steels – Part 4: Bar                  Testing of petroleum products and related products – Analysis by infrared spectrometry – General working principles                  Commission Decision 98/456/EC of 3 July 1998 on the procedure for attesting the conformity of construction products pursuant to Article 20(2) of Council Directive 89/106/EEC as regards post-tensioning kits for the prestressing of structures, Official Journal L 201 of 17 July 1998, page 112                  Regulation (EU) № 305/2011 of the European Parliament and of the Council of 9 March 2011 laying down harmonised conditions for the marketing of construction products and repealing Council Directive 89/106/EEC, Official Journal L 88 of 4 April 2011, page 5, as amended by Commission Delegated Regulation (EU) № 568/2014 of 18 February 2014, OJ L 157 of 27.5.2014, page 76 and Commission Delegated Regulation (EU) № 574/2014 of 21 February 2014, OJ L 159 of 28.5.2014, page 41                  Commission Delegated Regulation (EU) № 568/2014 of 18 February 2014 amending Annex V to Regulation (EU) № 305/2011 of the European Parliament and of the Council as regards the assessment and verification of constancy of performance of construction products, OJ L 157 of 27 May 2014, page 76</p>	